



**PROPRIETARY NOTE**  
THIS SPECIFICATION IS THE PROPERTY OF BOEDT AND SHALL NOT BE REPRODUCED OR COPIED WITHOUT THE WRITTEN PERMISSION OF BOEDT AND MUST BE RETURNED TO BOEDT UPON ITS REQUEST

SPEC. NUMBER	PRODUCT GROUP TFT-LCD	Rev.O	ISSUE DATE	PAGE 1 OF 35
--------------	--------------------------	-------	------------	-----------------

**TITLE :B4 NT116WHM-N10 Preliminary  
Product Specification Rev.O**

Beijing BOE Display Technology Co., Ltd

<b>PRODUCT GROUP</b>	REV	ISSUE DATE
TFT- LCD PRODUCT	0	
SPEC. NUMBER	B4 NT116WHQ-N10 Preliminary Product Specification Rev.0	PAGE 2 OF 35

### REVISION HISTORY

REV.	ECN No.	DESCRIPTION OF CHANGES	DATE	PREPARED
0		Initial Release	2014.04.01	于海峰

## Contents

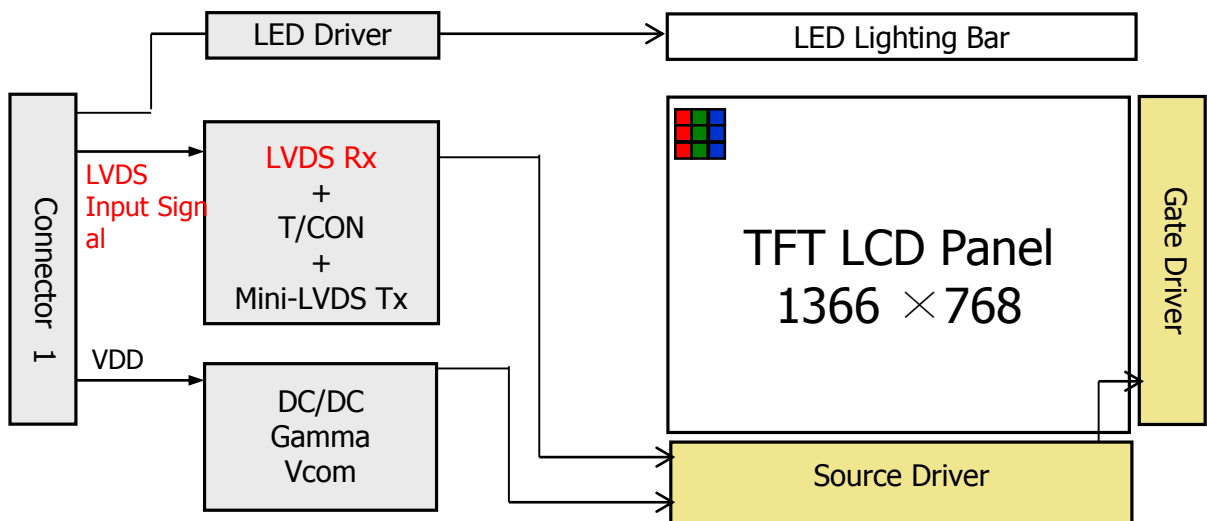
No.	Items	Page
1.0	General Description	4
2.0	Absolute Maximum ratings	6
3.0	Electrical specifications.	7
4.0	Optical specifications.	9
5.0	Interface Connection	14
6.0	Signal Timing Specification	18
7.0	Signal Timing waveforms	20
8.0	Input Signals, Display Colors & Gray Scale of Colors	22
9.0	Power Sequence	23
10.0	Connector description	24
11.0	Mechanical Characteristics	25
12.0	Reliability Test	26
13.0	Handling & Cautions.	26
14.0	Label	27
15.0	Packing information	29
16.0	Mechanical Outline Dimension	30
17.0	EDID Table	32

## 1.0 GENERAL DESCRIPTION

### 1.1 Introduction

NT116WHM-N10 is a color active matrix TFT LCD single cell using amorphous silicon TFT's (Thin Film Transistors) as an active switching devices. This module has a 11.6inch diagonally measured active area with WXGA resolutions ( 1366 horizontal by 768 vertical pixel array). Each pixel is divided into RED, GREEN, BLUE dots which are arranged in vertical stripe and this module can display 262,144 colors. The TFT-LCD panel used for this module is adapted for a low reflection and higher color type. Therefore, this module is suitable for Notebook PC. The LED Driver for back-light driving is built in this model.

All input signals are **LVDS** interface compatible.



### 1.2 Features

- **1 Channel LVDS Interface with 1 pixel / clock**
- Thin and light weight
- 6-bit color depth, display 262K colors
- Single LED Lighting Bar. (Top side/Horizontal Direction)
- Data enable signal mode
- Side Mounting Frame
- Green Product (RoHS & Halogen free product)
- On board LED Driving circuit
- Low driving voltage and low power consumption
- On board EDID chip

### 1.3 Application

- Notebook PC (Wide type)

### 1.4 General Specification

The followings are general specifications at the Module NT116WHM-N10.

<Table 1. General Specifications>

Parameter	Specification	Unit	Remarks
Active area	256.125 (H) × 144.00 (V)	mm	
Number of pixels	1366 (H) × 768 (V)	pixels	
Pixel pitch	0.1875(H) × 0.1875(V)	mm	
Pixel arrangement	RGB Vertical stripe		
Display colors	262K	colors	
Display mode	Normally White		
Dimensional outline	268±0.5(H)*168±0.5(V)*3.6(Max)	mm	
Weight	235 (max)	g	
Surface treatment	Anti-glare 3H		
Back-light	Upper edge side, 1-LED Lighting Bar type		Note 1
Power consumption	P <sub>D</sub> : 1.0 (max)	W	Note 2
	P <sub>B</sub> L : 1.8 (max)	W	
	P <sub>total</sub> : 2.8 (max)	W	

Notes : 1. LED Lighting Bar (24\*LED Array)

Notes: 2. Max Measurement Condition : : 32 checkboard pattern

## 2.0 ABSOLUTE MAXIMUM RATINGS

The followings are maximum values which, if exceed, may cause faulty operation or damage to the unit. The operational and non-operational maximum voltage and current values are listed in Table 2.

< Table 2. Absolute Maximum Ratings >

Ta=25+/-2°C

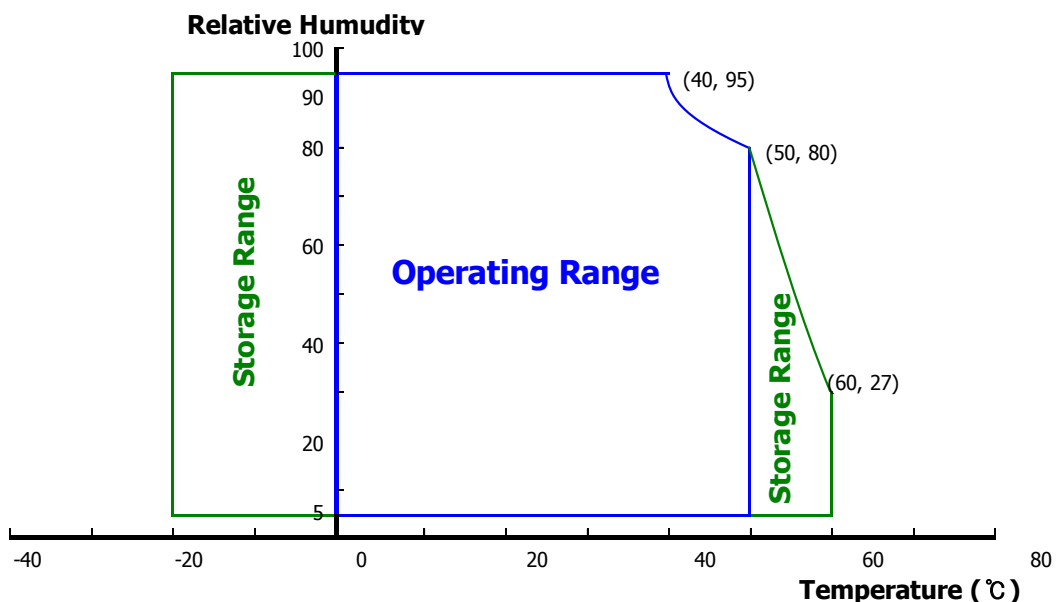
Parameter	Symbol	Min.	Max.	Unit	Remarks
Power Supply Voltage	V <sub>DD</sub>	-0.3	4.0	V	Note 1
Logic Supply Voltage	V <sub>IN</sub>	V <sub>SS</sub> -0.3	V <sub>DD</sub> +0.3	V	
Operating Temperature	T <sub>OP</sub>	0	+50	°C	Note 2
Storage Temperature	T <sub>ST</sub>	-20	+60	°C	

Notes : 1. Permanent damage to the device may occur if maximum values are exceeded functional operation should be restricted to the condition described under normal operating conditions.

2. Temperature and relative humidity range are shown in the figure below.

95 % RH Max. ( 40 °C ≥ Ta)

Maximum wet - bulb temperature at 39 °C or less. (Ta > 40 °C) No condensation.



### 3.0 ELECTRICAL SPECIFICATIONS

#### 3.1 Electrical Specifications

< Table 4. Electrical specifications >

Ta=25+/-2°C

Parameter		Min.	Typ.	Max.	Unit	Remarks
Power Supply Voltage	V <sub>DD</sub>	3.0	3.3	3.6	V	Note 1
Permissible Input Ripple Voltage	V <sub>RF</sub>	-	-	100	mV	At V <sub>DD</sub> = 3.3V
Power Supply Current	I <sub>DD</sub>	-	288	303	mA	Note 1
Positive-going Input Threshold Voltage	V <sub>IT+</sub>	-	-	100	mV	V <sub>cm</sub> = 1.2V typ.
Negative-going Input Threshold Voltage	V <sub>IT-</sub>	-100	-	-	mV	
Differential Input Voltage	V <sub>ID</sub>	380	-	1200	mV	
Power Consumption	P <sub>D</sub>	-	0.95	1.0	W	Note 1
	P <sub>BL</sub>	-	-	1.8	W	Note 2
	P <sub>total</sub>	-	-	2.8	W	

Notes : 1. The supply voltage is measured and specified at the interface connector of LCM.  
The current draw and power consumption specified is for 3.3V at 25°C.

a) Typ.: Gray level 255

b) Max : 32\*32 checkboard pattern



2. Calculated value for reference (V<sub>LED</sub> × I<sub>LED</sub>)

### 3.2 Backlight Unit

< Table 5. LED Driving guideline specifications >

Ta=25+/-2°C

Parameter		Min.	Typ.	Max.	Unit	Remarks
LED Forward Voltage	$V_F$	-	-	3.0	V	-
LED Forward Current	$I_F$	-	21.6		mA	-
LED Power Consumption	$P_{LED}$		-	1.8	W	Note 1
LED Life-Time	N/A	15,000	-	-	Hour	$I_F = 20mA$
Power supply voltage for LED Driver	$V_{LED}$	6	12	21	V	
EN Control Level	Backlight on	2.2		5.0	V	
	Backlight off	0		0.6	V	
PWM Control Level	PWM High Level	2.2		5.0	V	
	PWM Low Level	0		0.6	V	
PWM Control Frequency	$F_{PWM}$	180	-	10,000	Hz	
Duty Ratio	-	5	-	100	%	

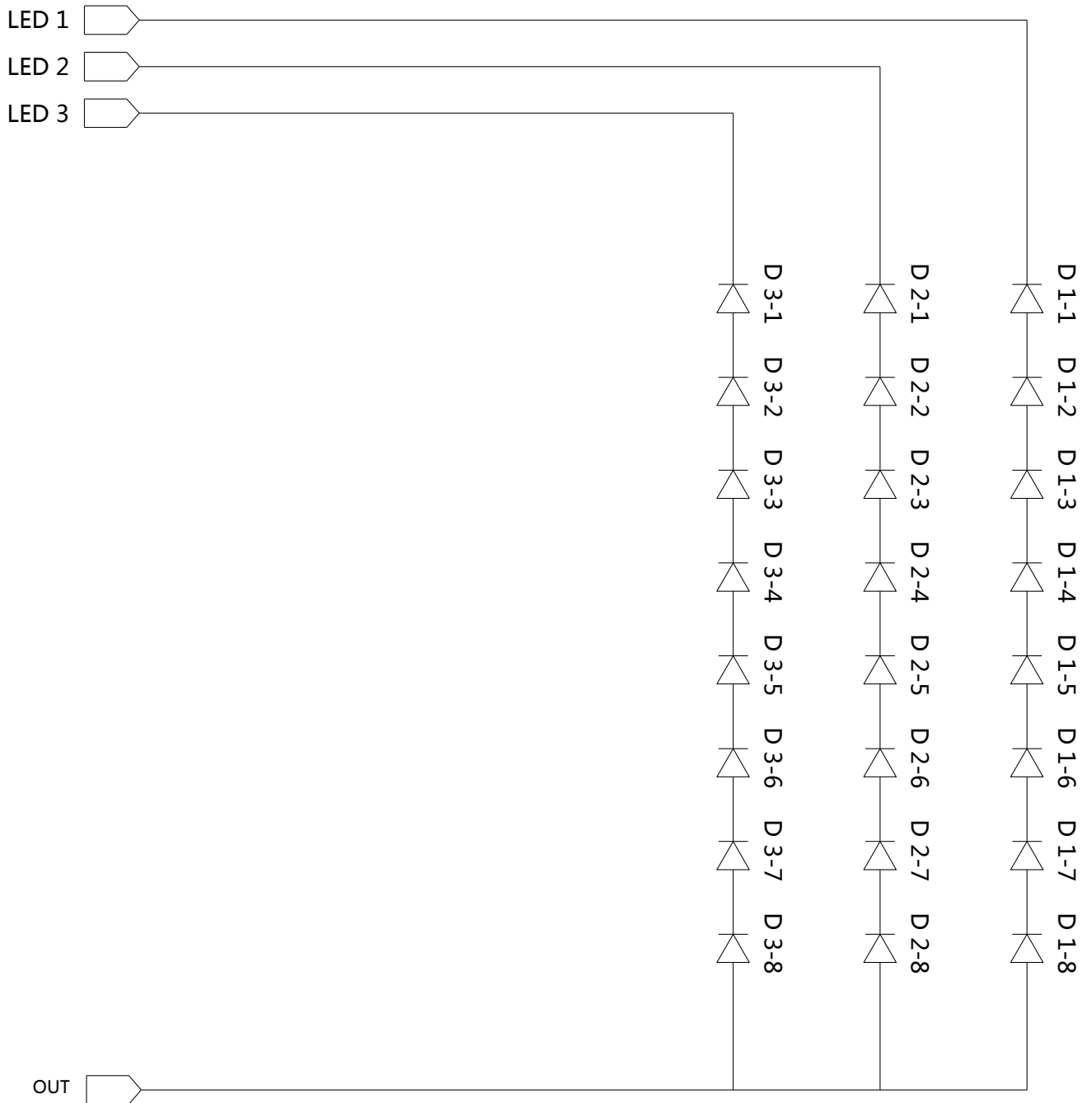
Notes : 1. Power supply voltage 12V for LED Driver, Driver efficiency 87%,

Calculator Value for reference  $I_F \times V_F \times 24 / 0.87 = P_{LED}$

2. The LED Life-time define as the estimated time to 50% degradation of initial luminous.



**3.3 LED structure 3\*8**



## 4.0 OPTICAL SPECIFICATION

### 4.1 Overview

The test of Optical specifications shall be measured in a dark room (ambient luminance  $\leq 1$  lux and temperature =  $25 \pm 2^\circ\text{C}$ ) with the equipment of Luminance meter system (Goniometer system and PR 730) and test unit shall be located at an approximate distance 50cm from the LCD surface at a viewing angle of  $\theta$  and  $\Phi$  equal to  $0^\circ$ . We refer to  $\theta\emptyset=0$  ( $=\theta_3$ ) as the 3 o'clock direction (the "right"),  $\theta\emptyset=90$  ( $=\theta_{12}$ ) as the 12 o'clock direction ("upward"),  $\theta\emptyset=180$  ( $=\theta_9$ ) as the 9 o'clock direction ("left") and  $\theta\emptyset=270$  ( $=\theta_6$ ) as the 6 o'clock direction ("bottom"). While scanning  $\theta$  and/or  $\emptyset$ , the center of the measuring spot on the Display surface shall stay fixed. The backlight should be operating for 30 minutes prior to measurement. VDD shall be  $3.3 \pm 0.3\text{V}$  at  $25^\circ\text{C}$ . Optimum viewing angle direction is 6 'clock.

### 4.2 Optical Specifications

<Table 6. Optical Specifications>

Parameter		Symbol	Condition	Min.	Typ.	Max.	Unit	Remark
Viewing Angle range	Horizontal	$\theta_3$	CR > 10	40	45	-	Deg.	Note 1
		$\theta_9$		40	45	-	Deg.	
	Vertical	$\theta_{12}$		15	20	-	Deg.	
		$\theta_6$		30	40	-	Deg.	
Luminance Contrast ratio		CR	$\Theta = 0^\circ$	450	500			Note 2
Luminance of White	5 Points	$Y_w$	$\Theta = 0^\circ$ ILED = 21.6mA	200	220	-	cd/m <sup>2</sup>	Note 3
White Luminance uniformity	5 Points	$\Delta Y_5$		78	-	-		Note 4
	13 Points	$\Delta Y_{13}$		60	-	-		
White Chromaticity		$x_w$	$\Theta = 0^\circ$	0.283	0.313	0.343		Note 5
		$y_w$		0.299	0.329	0.359		
Reproduction of color	Red	$x_R$	$\Theta = 0^\circ$	0.560	0.580	0.600		
		$y_R$					0.357	
	Green	$x_G$		Typ-0.3	0.580	Typ+0.3	0.343	
		$y_G$					0.162	
	Blue	$x_B$		0.110				
		$y_B$						
Color Gamut				-	45	-	%	
Response Time (Rising + Falling)		$T_{RT}$	Ta= $25^\circ\text{C}$ $\Theta = 0^\circ$	-	12	16	ms	Note 6
Cross Talk		CT	$\Theta = 0^\circ$	-	-	2.0	%	Note 7

**Notes :**

1. Viewing angle is the angle at which the contrast ratio is greater than 10. The viewing angles are determined for the horizontal or 3, 9 o'clock direction and the vertical or 6, 12 o'clock direction with respect to the optical axis which is normal to the LCD surface (see FIGURE 1).

2. Contrast measurements shall be made at viewing angle of  $\Theta = 0$  and at the center of the LCD surface. Luminance shall be measured with all pixels in the view field set first to white, then to the dark (black) state .  
(see FIGURE 1) Luminance Contrast Ratio (CR) is defined mathematically.

$$CR = \frac{\text{Luminance when displaying a white raster}}{\text{Luminance when displaying a black raster}}$$

3. (with TP) Center Luminance of white is defined as luminance values of 5 point average across the LCD surface. Luminance shall be measured with all pixels in the view field set first to white. This measurement shall be taken at the locations shown in FIGURE 2 for a total of the measurements per display.

4. The White luminance uniformity on LCD surface is then expressed as :  $\Delta Y = \text{Minimum Luminance of 5(or 13) points} / \text{Maximum Luminance of 5(or 13) points}$ .  
(see FIGURE 2 and FIGURE 3).

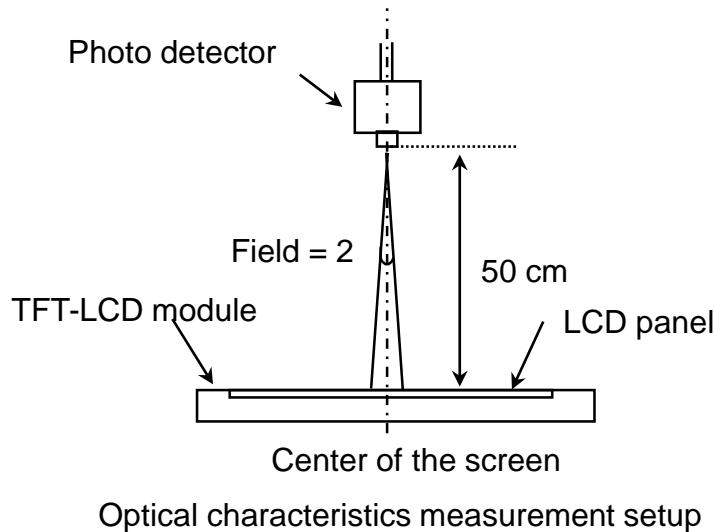
5. The color chromaticity coordinates specified in Table 5 shall be calculated from the spectral data measured with all pixels first in red, green, blue and white. Measurements shall be made at the center of the panel.

6. The electro-optical response time measurements shall be made as FIGURE 4 by switching the "data" input signal ON and OFF. The times needed for the luminance to change from 10% to 90% is  $T_r$ , and 90% to 10% is  $T_d$ .

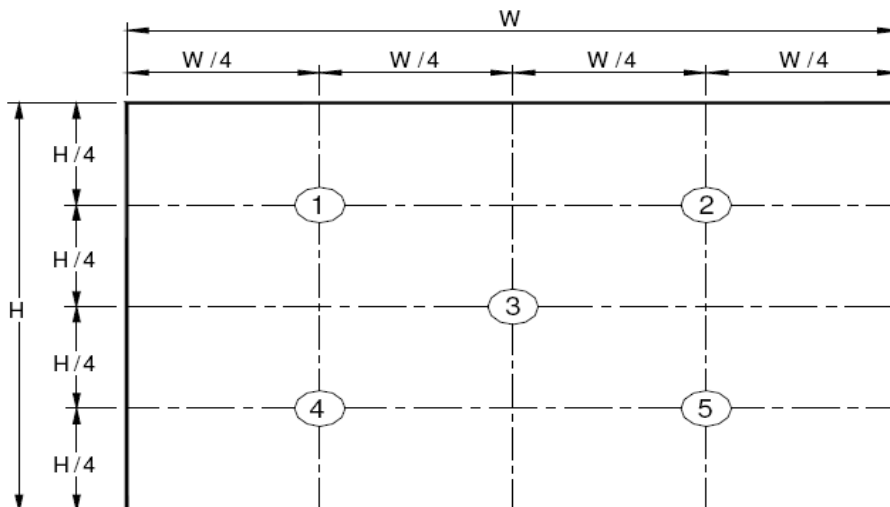
7. Cross-Talk of one area of the LCD surface by another shall be measured by comparing the luminance (YA) of a 25mm diameter area, with all display pixels set to a gray level, to the luminance (YB) of that same area when any adjacent area is driven dark.  
(See FIGURE 5).

### 4.3 Optical measurements

**Figure 1. Measurement Set Up**

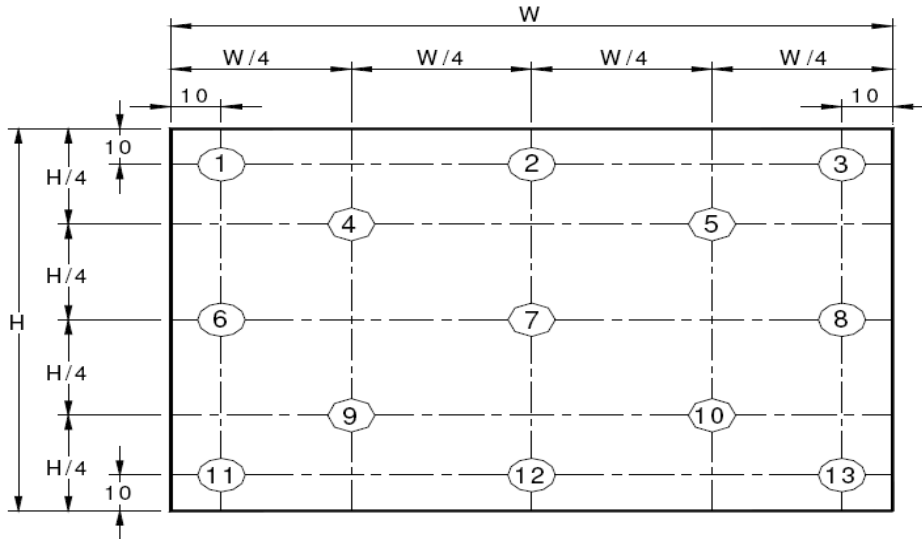


**Figure 2. White Luminance and Uniformity Measurement Locations (5 points)**



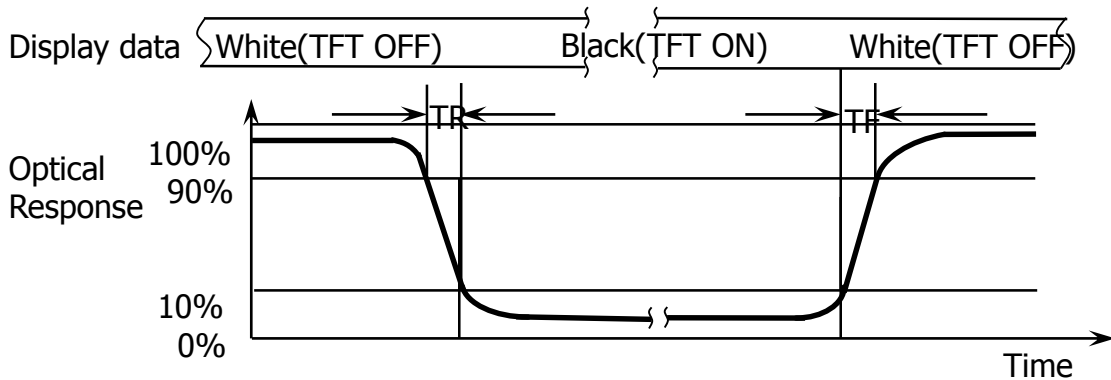
Center Luminance of white is defined as luminance values of center 5 points across the LCD surface. Luminance shall be measured with all pixels in the view field set first to white. This measurement shall be taken at the locations shown in FIGURE 2 for a total of the measurements per display.

**Figure 3. Uniformity Measurement Locations (13 points)**

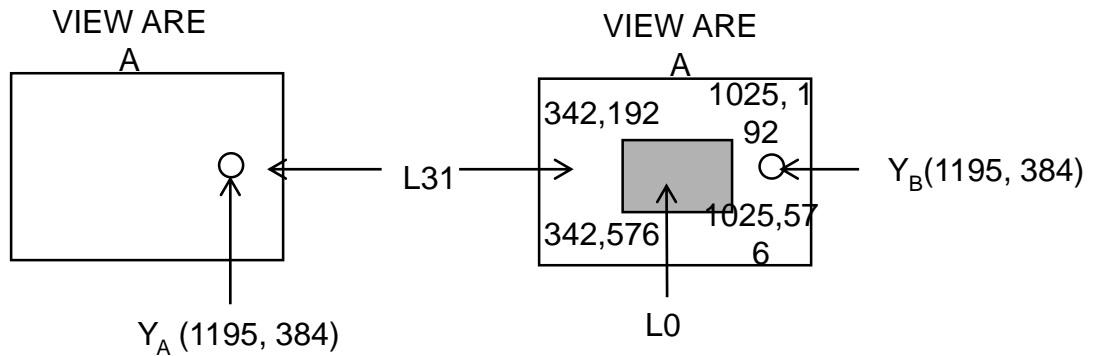


The White luminance uniformity on LCD surface is then expressed as :  $\Delta Y_5 = \text{Minimum Luminance of five points} / \text{Maximum Luminance of five points}$  (see FIGURE 2) ,  $\Delta Y_{13} = \text{Minimum Luminance of 13 points} / \text{Maximum Luminance of 13 points}$  (see FIGURE 3).

**Figure 4. Response Time Testing**



The electro-optical response time measurements shall be made as shown in FIGURE 4 by switching the “data” input signal ON and OFF. The times needed for the luminance to change from 10% to 90% is  $T_d$  and 90% to 10% is  $T_r$ .

**Figure 5. Cross Modulation Test Description**


$$\text{Cross-Talk (\%)} = \left| \frac{Y_B - Y_A}{Y_A} \right| \times 100$$

Where:

$Y_A$  = Initial luminance of measured area ( $\text{cd/m}^2$ )

$Y_B$  = Subsequent luminance of measured area ( $\text{cd/m}^2$ )

The location measured will be exactly the same in both patterns

Cross-Talk of one area of the LCD surface by another shall be measured by comparing the luminance ( $Y_A$ ) of a 25mm diameter area, with all display pixels set to a gray level, to the luminance ( $Y_B$ ) of that same area when any adjacent area is driven dark (Refer to FIGURE 5).

**5.0 INTERFACE CONNECTION.**
**5.1 Electrical Interface Connection**

The electronics interface connector is UJU. The mating connector part number is I-PEX 20455-040T-11 or Compatible. The connector interface pin assignments are listed in Table 6.

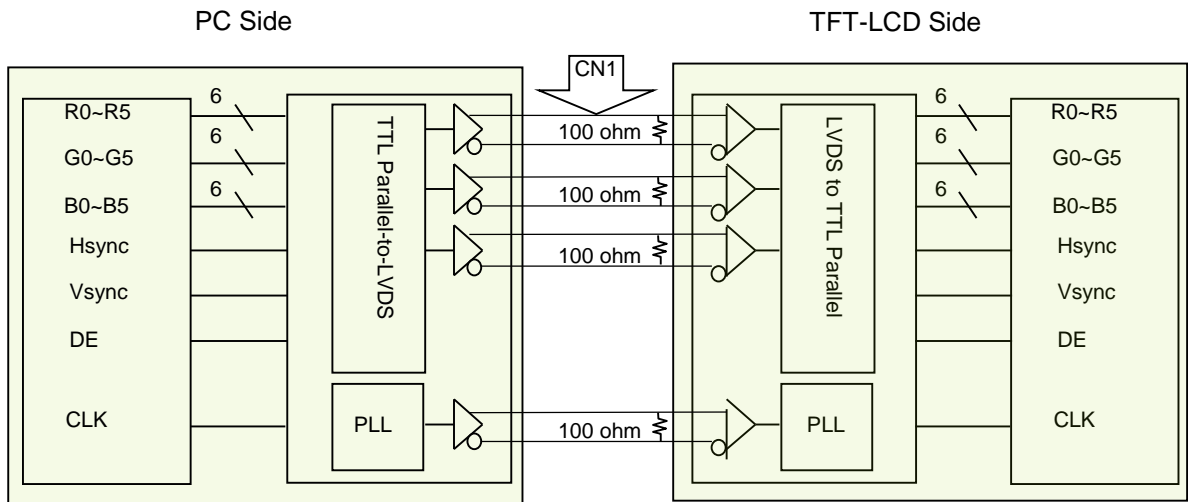
<Table 6. Pin Assignments for the Interface Connector>

<b>Terminal</b>	<b>Symbol</b>	<b>Functions</b>
<b>Pin No.</b>	<b>Symbol</b>	<b>Description</b>
1	NC	No Connection
2	VDDIN	Power Supply, 3.3V (typ.)
3	VDDIN	Power Supply, 3.3V (typ.)
4	VDC	VDC 3.3Vpower for EDID
5	NC	No Connection
6	CLK EDID	EDID Clock
7	Data EDID	EDID Data
8	RxIN0-	Transmission Data of 0 Negative -
9	RxIN0+	Transmission Data of 0 Positive +
10	GND	Ground
11	RxIN1-	Transmission Data of 1 Negative -
12	RxIN1+	Transmission Data of 1 Positive +
13	GND	Ground
14	RxIN2-	Transmission Data of 2 Negative -
15	RxIN2+	Transmission Data of 2 Positive +
16	GND	Ground
17	RxCLKIN-	Sampling Clock of Negative -
18	RxCLKIN+	Sampling Clock of Positive +
19	NC	No Connection
20	NC	No Connection
21	NC	No Connection
22	GND	Ground
23	NC	No Connection
24	NC	No Connection
25	GND	Ground
26	NC	No Connection
27	NC	No Connection
28	GND	Ground
29	NC	No Connection
30	NC	No Connection

<b>Terminal</b>	<b>Symbol</b>	<b>Functions</b>
<b>Pin No.</b>	<b>Symbol</b>	<b>Description</b>
31	VLED_GND	LED Ground
32	VLED_GND	LED Ground
33	VLED_GND	LED Ground
34	NC	No Connection
35	PWM	System PWM Signal Input
36	LED_EN	LED enable pin(+3.3V Input)
37	NC	No Connection
38	VLED	LED Power Supply 6V-21V
39	VLED	LED Power Supply 6V-21V
40	VLED	LED Power Supply 6V-21V

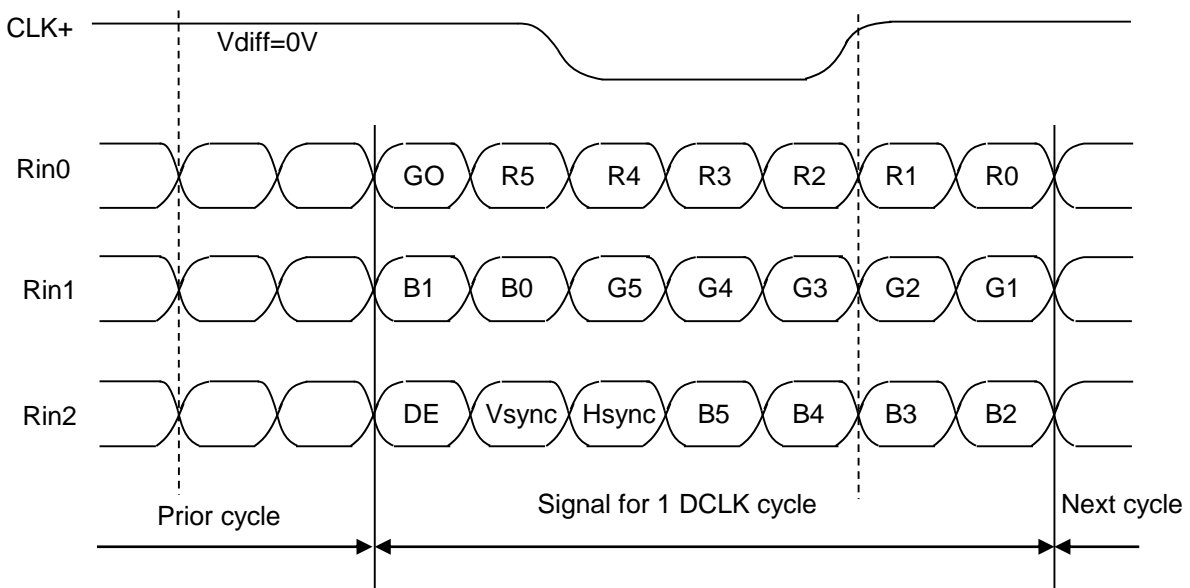


## 5-2. LVDS Interface



Note. Transmitter : Thine THC63LVDM63A or equivalent.  
Transmitter is not contained in Module.

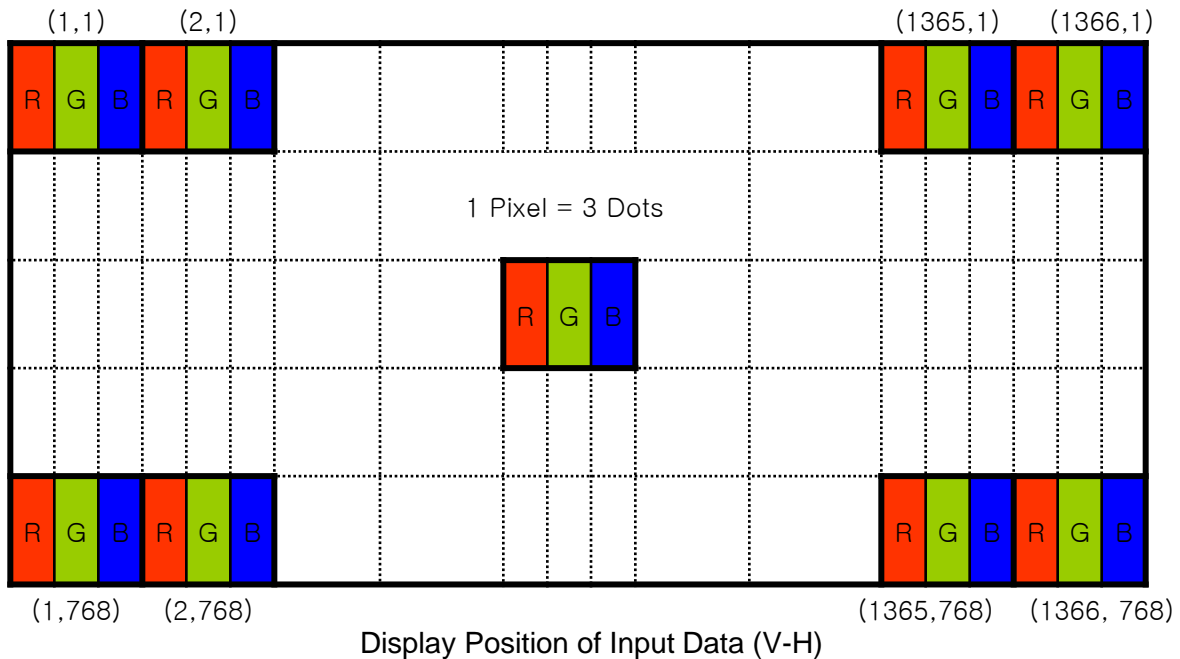
## 5.3.LVDS Input signal



Note. Pin connection in case of using Thine  
THC63LVDM63A

## 5.3 Data Input Format

<Table 6. Pin Assignments for the Interface Connector>



## 5.4 Back-light & LCM Interface Connection

Interface Connector: PF040-B09B-C09 or Equivalent

<Table 7. Pin Assignments for the BLU & LCM Connector>

Pin No.	Symbol	Description	Pin No.	Symbol	Description
1	LED1	LED cathode connection	6	NC	No Connection
2	LED2	LED cathode connection	7	Vout	LED anode connection
3	LED3	LED cathode connection	8	Vout	LED anode connection
4	NC	No Connection	9	Vout	LED anode connection
5	NC	No Connection			

## 6.0 SIGNAL TIMING SPECIFICATION

### 6.1 The 11.6 is operated by the DE only

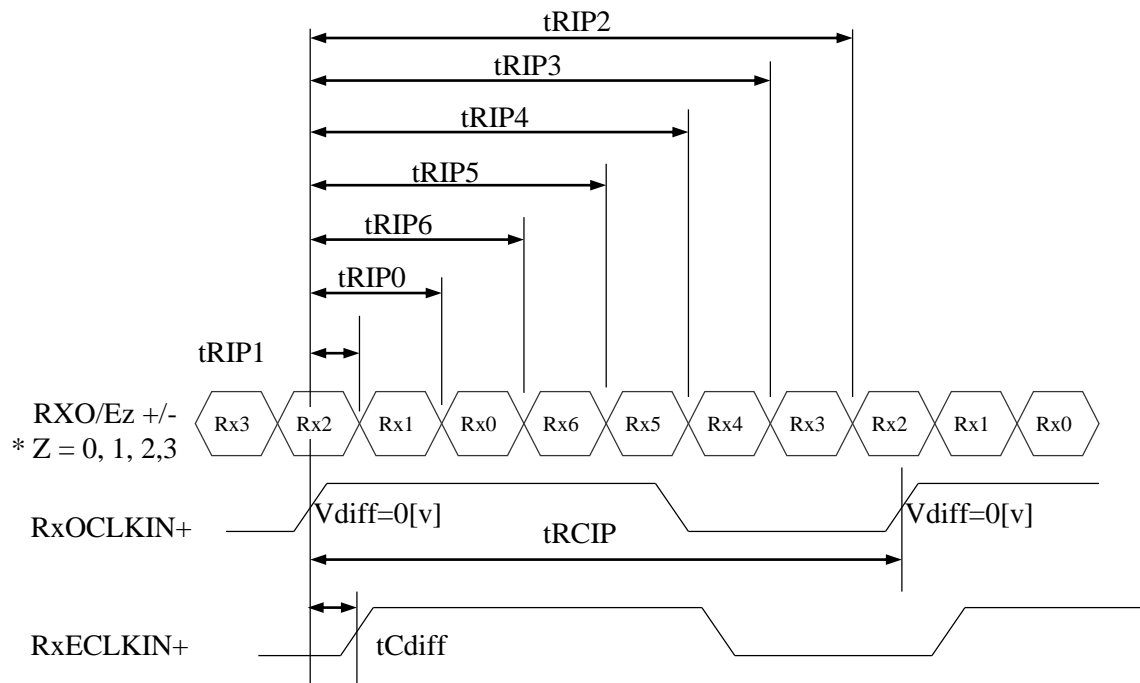
Item		Symbols	Min	Typ	Max	Unit
Clock	Frequency	1/Tc	67.5	76.3	78.2	MHz
	High Time	Tch	-	4/7	-	Tc
	Low Time	Tcl	-	3/7	-	Tc
Frame Period		Tv	778	790	802	lines
			-	60	-	Hz
			-	16.7	-	ms
Vertical Display Period		Tvd	768	768	768	lines
One line Scanning Period		Th	1446	1610	1625	clocks
Horizontal Display Period		Thd	1366	1366	1366	clocks

## 6.2 LVDS Rx Interface Timing Parameter

The specification of the LVDS Rx interface timing parameter is shown in Table 8.

<Table 8. LVDS Rx Interface Timing Specification>

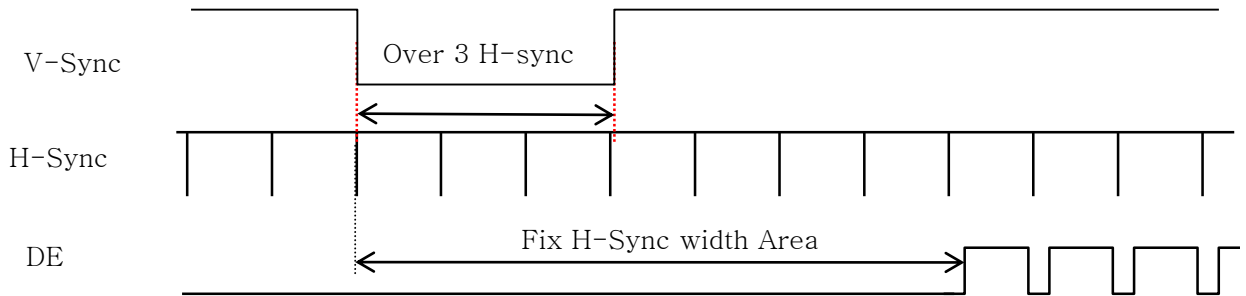
Item	Symbol	Min	Typ	Max	Unit	Remark
CLKIN Period	tRCIP	-	13.83	25	nsec	
CLK Difference	tCdiff	-tRCIP*(3/7)	0	+tRCIP*(3/7)	nsec	
Input Data 0	tRIP1	-0.4	0.0	+0.4	nsec	
Input Data 1	tRIP0	tRCIP/7-0.4	tRCIP/7	tRCIP/7+0.4	nsec	
Input Data 2	tRIP6	2 × tRCIP/7-0.4	2 × tRCIP/7	2 × tRCIP/7+0.4	nsec	
Input Data 3	tRIP5	3 × tRCIP/7-0.4	3 × tRCIP/7	3 × tRCIP/7+0.4	nsec	
Input Data 4	tRIP4	4 × tRCIP/7-0.4	4 × tRCIP/7	4 × tRCIP/7+0.4	nsec	
Input Data 5	tRIP3	5 × tRCIP/7-0.4	5 × tRCIP/7	5 × tRCIP/7+0.4	nsec	
Input Data 6	tRIP2	6 × tRCIP/7-0.4	6 × tRCIP/7	6 × tRCIP/7+0.4	nsec	



\* Vdiff = (RXO/Ez+)-(RXO/Ez-),.... ,(RXO/ECLK+)-(RXO/ECLK-)

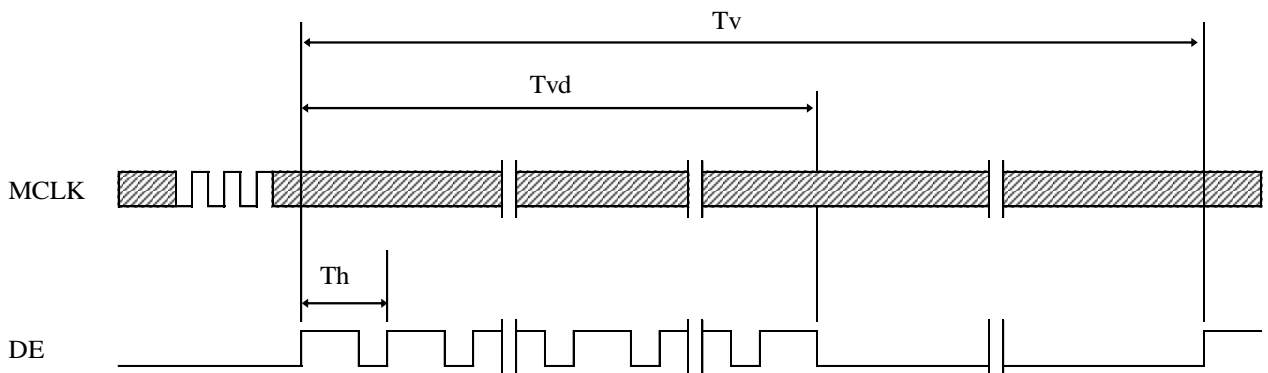
## 7.0 SIGNAL TIMING WAVEFORMS OF INTERFACE SIGNAL

### 7.1 Sync Timing Waveforms

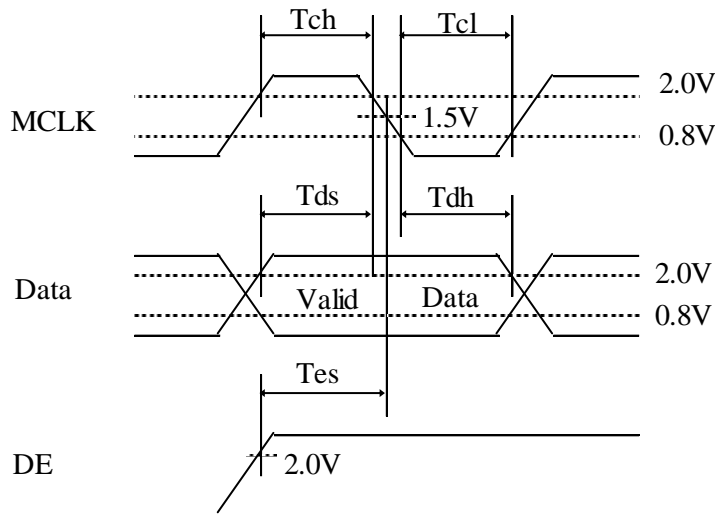
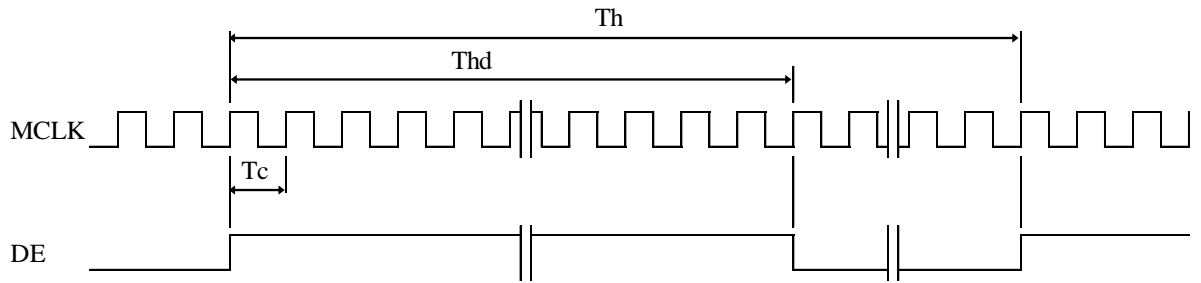


- 1) Need over 3 H-sync during V-Sync Low
- 2) Fix H-Sync width from V-Sync falling edge to first rising edge

### 7.2 Vertical Timing Waveforms



## 7.3 Horizontal Timing Waveforms

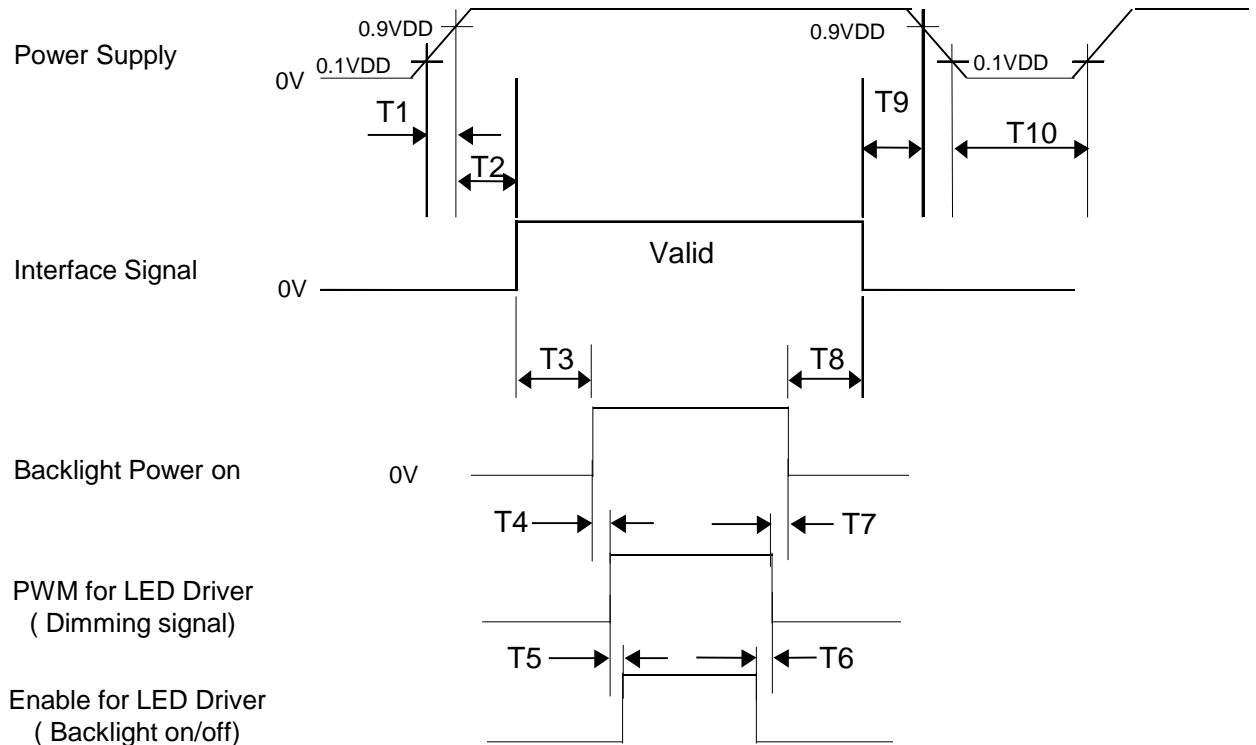


**7.0 INPUT SIGNALS, BASIC DISPLAY COLORS & GRAY SCALE OF COLORS**

	Colors & Gray scale	Data signal																	
		R0	R1	R2	R3	R4	R5	G0	G1	G2	G3	G4	G5	B0	B1	B2	B3	B4	B5
Basic colors	Black	0	0	0	0	0	0	0	0	0	0	0	0	0	0	0	0	0	0
	Blue	0	0	0	0	0	0	0	0	0	0	0	0	1	1	1	1	1	1
	Green	0	0	0	0	0	0	1	1	1	1	1	1	0	0	0	0	0	0
	Light Blue	0	0	0	0	0	0	1	1	1	1	1	1	1	1	1	1	1	1
	Red	1	1	1	1	1	1	0	0	0	0	0	0	0	0	0	0	0	0
	Purple	1	1	1	1	1	1	0	0	0	0	0	0	1	1	1	1	1	1
	Yellow	1	1	1	1	1	1	1	1	1	1	1	1	0	0	0	0	0	0
	White	1	1	1	1	1	1	1	1	1	1	1	1	1	1	1	1	1	1
Gray scale of Red	Black	0	0	0	0	0	0	0	0	0	0	0	0	0	0	0	0	0	0
	△	1	0	0	0	0	0	0	0	0	0	0	0	0	0	0	0	0	0
	Darker	0	1	0	0	0	0	0	0	0	0	0	0	0	0	0	0	0	0
	△	↑						↑						↑					
	▽	↓						↓						↓					
	Brighter	1	0	1	1	1	1	0	0	0	0	0	0	0	0	0	0	0	0
	▽	0	1	1	1	1	1	0	0	0	0	0	0	0	0	0	0	0	0
Red	1	1	1	1	1	1	0	0	0	0	0	0	0	0	0	0	0	0	
Gray scale of Green	Black	0	0	0	0	0	0	0	0	0	0	0	0	0	0	0	0	0	0
	△	0	0	0	0	0	0	1	0	0	0	0	0	0	0	0	0	0	0
	Darker	0	0	0	0	0	0	0	1	0	0	0	0	0	0	0	0	0	0
	△	↑						↑						↑					
	▽	↓						↓						↓					
	Brighter	0	0	0	0	0	0	1	0	1	1	1	1	0	0	0	0	0	0
	▽	0	0	0	0	0	0	0	1	1	1	1	1	0	0	0	0	0	0
Green	0	0	0	0	0	0	1	1	1	1	1	1	0	0	0	0	0	0	
Gray scale of Blue	Black	0	0	0	0	0	0	0	0	0	0	0	0	0	0	0	0	0	0
	△	0	0	0	0	0	0	0	0	0	0	0	0	1	0	0	0	0	0
	Darker	0	0	0	0	0	0	0	0	0	0	0	0	0	1	0	0	0	0
	△	↑						↓						↑					
	▽	↓						↓						↓					
	Brighter	0	0	0	0	0	0	0	0	0	0	0	0	1	0	1	1	1	1
	▽	0	0	0	0	0	0	0	0	0	0	0	0	0	1	1	1	1	1
Blue	0	0	0	0	0	0	0	0	0	0	0	0	1	1	1	1	1	1	
Gray scale of White & Black	Black	0	0	0	0	0	0	0	0	0	0	0	0	0	0	0	0	0	0
	△	1	0	0	0	0	0	1	0	0	0	0	0	1	0	0	0	0	0
	Darker	0	1	0	0	0	0	0	1	0	0	0	0	0	1	0	0	0	0
	△	↑						↑						↑					
	▽	↓						↓						↓					
	Brighter	1	0	1	1	1	1	1	0	1	1	1	1	1	0	1	1	1	1
	▽	0	1	1	1	1	1	0	1	1	1	1	1	0	1	1	1	1	1
White	1	1	1	1	1	1	1	1	1	1	1	1	1	1	1	1	1	1	

## 8.0 POWER SEQUENCE

To prevent a latch-up or DC operation of the LCD module, the power on/off sequence shall be as shown in below



- $T1 \leq 10 \text{ ms}$
- $0 \text{ ms} \leq T2 \leq 50 \text{ ms}$
- $200 \text{ ms} \leq T3$
- $10 \text{ ms} \leq T4$
- $10 \text{ ms} \leq T5$
- $0 \text{ ms} \leq T6$
- $10 \text{ ms} \leq T7$
- $200 \text{ ms} \leq T8$
- $0 \text{ ms} \leq T9 \leq 50 \text{ ms}$
- $1 \text{ s} \leq T10$

### Notes:

- When the power supply VDD is 0V, keep the level of input signals on the low or keep high impedance.
- Do not keep the interface signal high impedance when power is on. Back Light must be turn on after power for logic and interface signal are valid.



## 9.0 Connector Description

Physical interface is described as for the connector on LCM.

These connectors are capable of accommodating the following signals and will be following components.

### 9.1 TFT LCD Module

Connector Name /Description	For Signal Connector
Manufacturer	IPEX or Compatible
Type/ Part Number	I-PEX 20455-040E-12 or Compatible
Mating housing/ Part Number	I-PEX 20455-040T-11 or Compatible

## 10.0 MECHANICAL CHARACTERISTICS

### 10.1 Dimensional Requirements

FIGURE 6 shows mechanical outlines for the model 11.6 Ultra Slim.  
Other parameters are shown in Table 10.

<Table 10. Dimensional Parameters>

Parameter	Specification	Unit
Active Area	256.125 (H) × 144 (V)	
Number of pixels	1366 (H) × 768 (V)	
Pixel pitch	0.1875 (H) X 0.1875 (V)	
Pixel arrangement	RGB Vertical stripe	
Display colors	262K	
Display mode	Normally white	
Dimensional outline	268±0.5(H)*168±0.5(V)*3.6(Max)	mm
Weight	235 (max)	gram

### 10.2 Mounting

See FIGURE 6.

### 10.3 Anti-Glare and Polarizer Hardness.

The surface of the LCD has an AG coating to minimize reflection and a coating to reduce scratching.

### 10.4 Light Leakage

There shall not be visible light from the back-lighting system around the edges of the screen as seen from a distance 50cm from the screen with an overhead light level of 350lux.

## 11.0 RELIABILITY TEST

The Reliability test items and its conditions are shown in below.

<Table 11. Reliability test>

No	Test Items	Conditions
1	High temperature storage test	Ta = 60 °C, 240 hrs
2	Low temperature storage test	Ta = -20 °C, 240 hrs
3	High temperature & high humidity operation test	Ta = 50 °C, 80%RH, 240 hrs
4	High temperature operation test	Ta = 50 °C, 240 hrs
5	Low temperature operation test	Ta = 0 °C, 240 hrs
6	Thermal shock	Ta = -20 °C ↔ 60 °C (0.5 hr), 100 cycle
7	Vibration test (non-operating)	1.5G, 10~500Hz, Half Sine X,Y,Z / Sweep rate : 1 hour
8	Shock test (non-operating)	220G, Half Sine Wave 2msec ± X, ± Y, ± Z Once for each direction
9	Electro-static discharge test (non-operating)	Air : 150 pF, 330Ω, 15 KV Contact : 150 pF, 330Ω, 8 KV

## 12.0 HANDLING & CAUTIONS

### (1) Cautions when taking out the module

- Pick the pouch only, when taking out module from a shipping package.

### (2) Cautions for handling the module

- As the electrostatic discharges may break the LCD module, handle the LCD module with care. Peel a protection sheet off from the LCD panel surface as slowly as possible.
- As the LCD panel and back - light element are made from fragile glass material, impulse and pressure to the LCD module should be avoided.
- As the surface of the polarizer is very soft and easily scratched, use a soft dry cloth without chemicals for cleaning.
- Do not pull the interface connector in or out while the LCD module is operating.
- Put the module display side down on a flat horizontal plane.
- Handle connectors and cables with care.

### (3) Cautions for the operation

- When the module is operating, do not lose CLK, ENAB signals. If any one of these signals is lost, the LCD panel would be damaged.
- Obey the supply voltage sequence. If wrong sequence is applied, the module would be damaged.

**(4) Cautions for the atmosphere**

- Dew drop atmosphere should be avoided.
- Do not store and/or operate the LCD module in a high temperature and/or humidity atmosphere. Storage in an electro-conductive polymer packing pouch and under relatively low temperature atmosphere is recommended.

**(5) Cautions for the module characteristics**

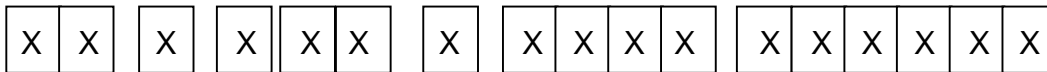
- Do not apply fixed pattern data signal to the LCD module at product aging.
- Applying fixed pattern for a long time may cause image sticking.

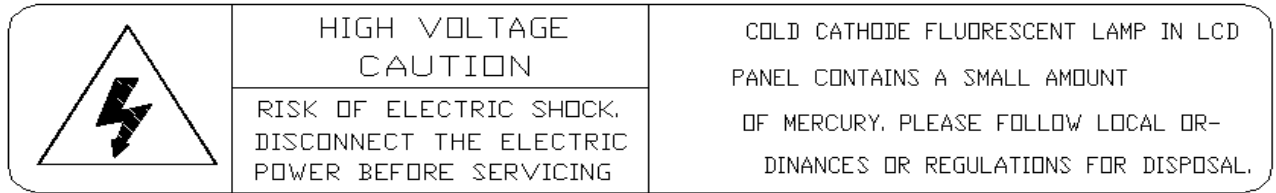
**(6) Other cautions**

- Do not disassemble and/or re-assemble LCD module.
- Do not re-adjust variable resistor or switch etc.
- When returning the module for repair or etc., Please pack the module not to be broken. We recommend to use the original shipping packages.

**13.0 LABEL**
**(1) Product label**


1      2      3      4      5      6      7


**Type designation**
**No 5. Month (1, 2, 3, ..., 9, X, Y, Z)**
**No 1. Control Number**
**No 6. Product Identification (FG)**
**No 2. Rank / Grade**
**No 7. Serial Number**
**No 3. Line classification**
**No 4. Year (10 : 2010, 11: 2011, ...)**

**(2) High voltage caution label**

**(3) Box label**

Label Size: 110 mm (L) × 56 mm (W)

Contents

Model: NT116WHM-N10

Q`ty: Module Q`ty in one box

Serial No.: Box Serial No. See next figure for detail description.

Date: Packing Date

Internal use of Product



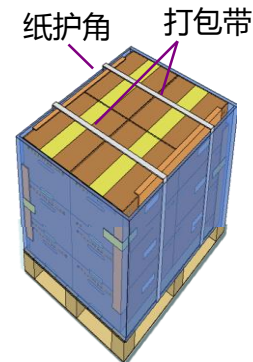
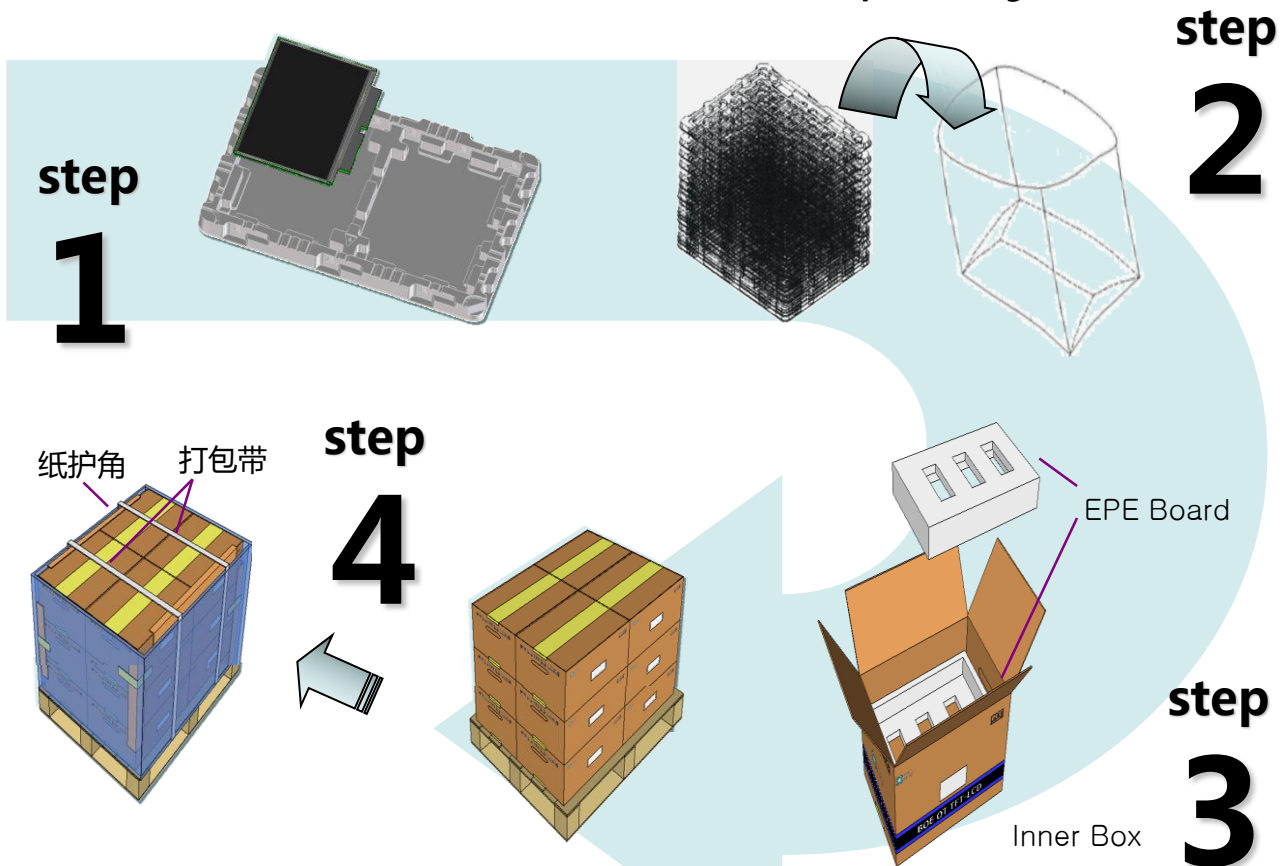
<u>00</u>	<u>0</u>	<u>0</u>	<u>00</u>	<u>0</u>	<u>0000</u>	<u>000000</u>
Type	Grade	Line	Year	Month	Internal use	Serial No

## 14.0 PACKING INFORMATION

### 14.1 Packing order

- 将 2pcs MDL 平放入Tray, Panel 面向上放置
- 容量: 2pcs/Tray

- 将21pcs PET Tray 平放入PE Bag
- 人工方式 ;
- 容量: 40pcs/PE Bag



- 每个Pallet上放3层Box, 1层4箱,共计12ea Box
- Pallet 四边及打包带位置放置纸护角后,以缠绕膜包裹
- 容量: 480pcs/Pallet

- 将PET Tray堆码后平放入Inner Box,上下放置EPE Board
- 人工方式
- 容量 : 40pcs/Inner Box

### 14.2 Notes

- Box Dimension: 550mm(W) x 470mm(D) x 290mm(H)
- Package Quantity in one Box: 40pcs
- Total Weight: 16kg

## 15.0 MECHANICAL OUTLINE DIMENSION

Figure 6. TFT-LCD Module Outline Dimension (Front View)

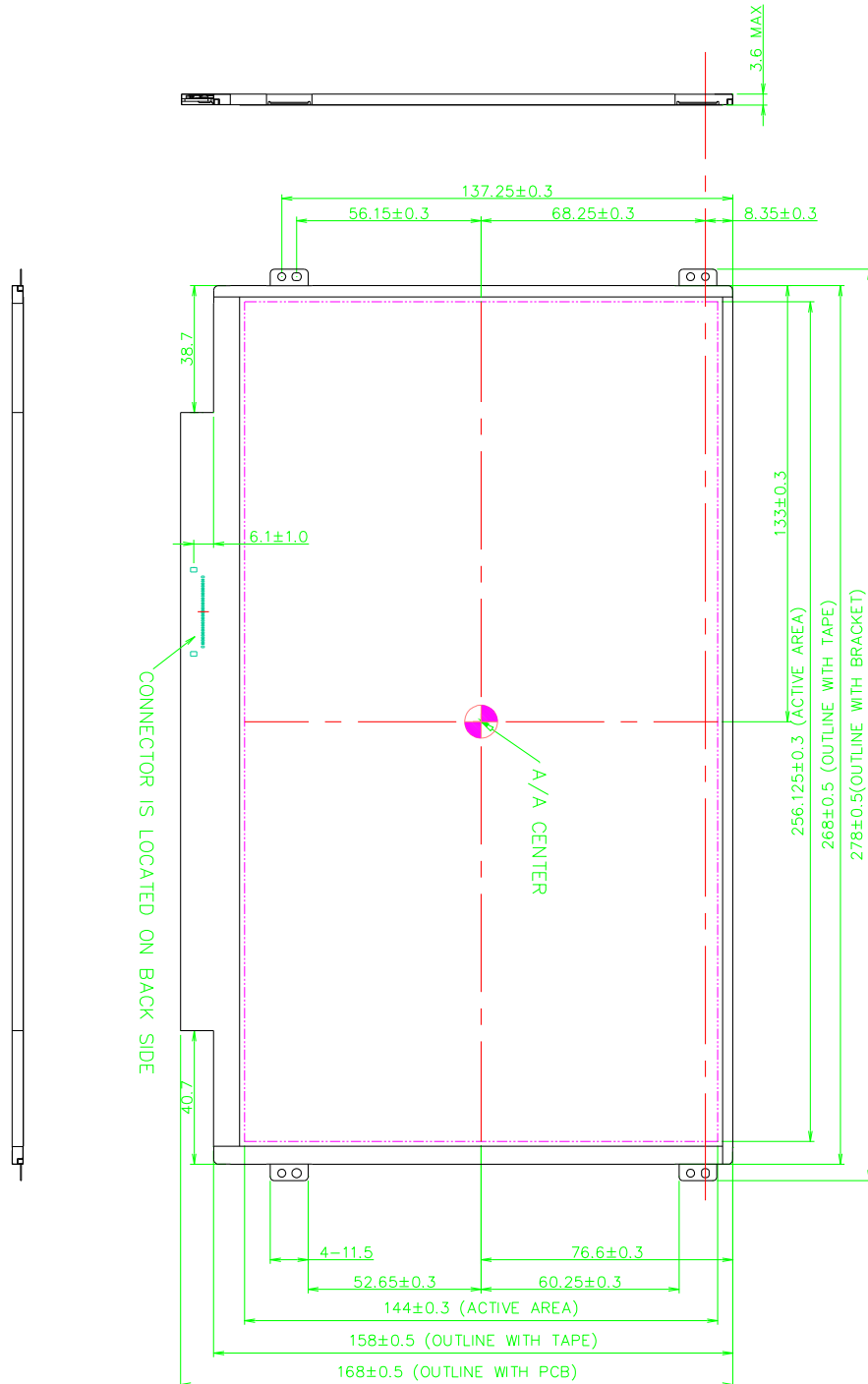
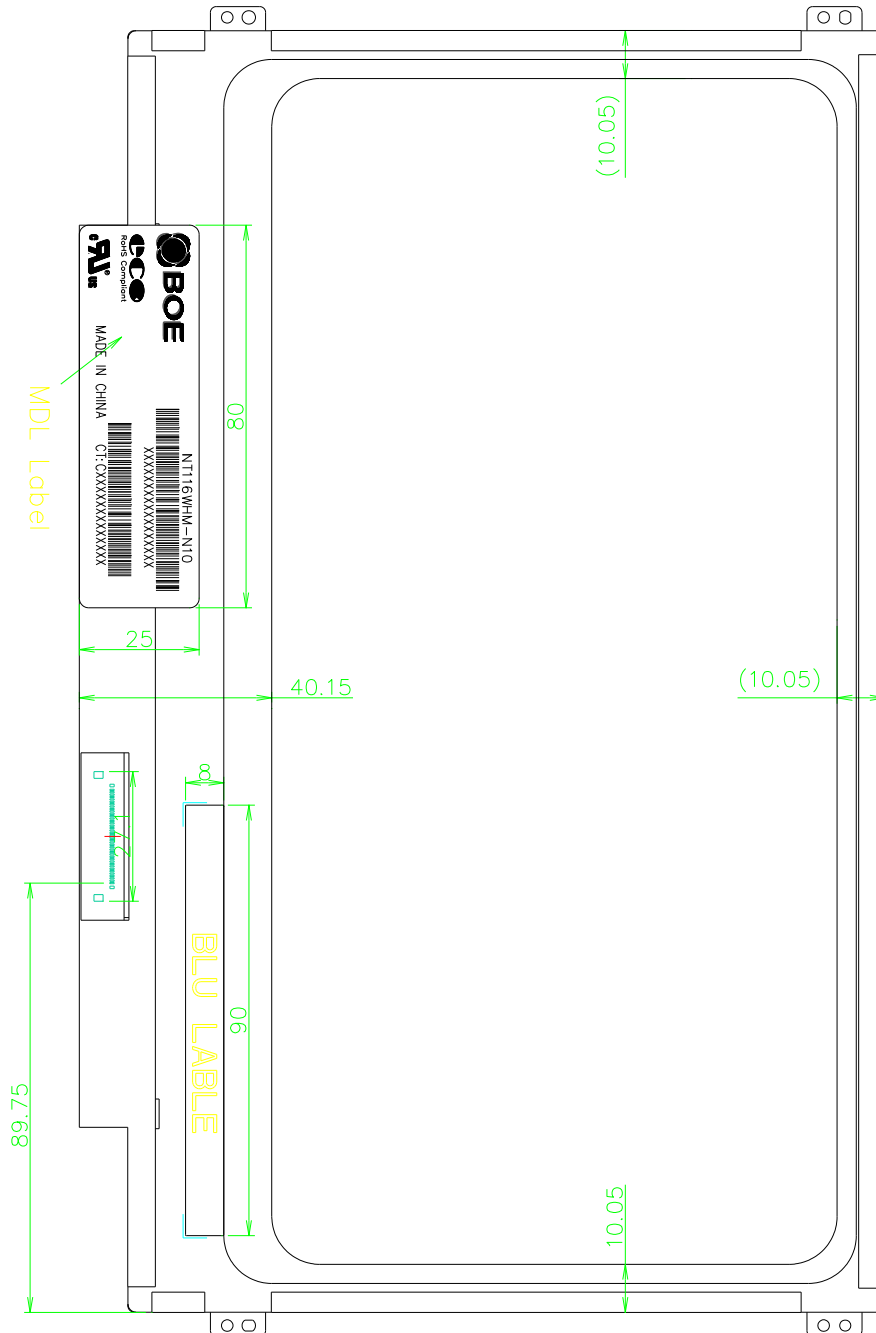


Figure 7. TFT-LCD Module Outline Dimensions (Rear view)





**16.0 EDID Table**

Address (HEX)	Function	Hex	Dec	crc	Input values.	Notes
00	Header	00	0		0	EDID Header
01		FF	255		255	
02		FF	255		255	
03		FF	255		255	
04		FF	255		255	
05		FF	255		255	
06		FF	255		255	
07		00	0		0	
08	ID Manufacturer Name	09	9		BOE	ID = BOE
09		E5	229			
0A	ID Product Code	1C	28		1564	ID = 1564
0B		06	6			
0C	32-bit serial No.	00	0			
0D		00	0			
0E		00	0			
0F		00	0			
10	Week of manufacture	01	1		1	
11	Year of Manufacture	18	24		2014	Manufactured in 2014
12	EDID Structure Ver.	01	1		1	EDID Ver 1.0
13	EDID revision #	04	4		4	EDID Rev. 0.4
14	Video input definition	95	149		-	digital signal/DP input
15	Max H image size	1A	26		26	26 cm (Approx)
16	Max V image size	0F	15		15	15 cm (Approx)
17	Display Gamma	78	120		2.2	Gamma curve = 2.2
18	Feature support	0A	10			RGB display, Preferred Timming mode
19	Red/Green low bits	5D	93		-	Red / Green Low Bits
1A	Blue/White low bits	40	64		-	Blue / White Low Bits
1B	Red x high bits	94	148	593	0.58	Red (x) = 10010100 (0.58)
1C	Red y high bits	5B	91	365	0.357	Red (y) = 01011011 (0.357)
1D	Green x high bits	57	87	351	0.343	Green (x) = 01010111 (0.343)
1E	Green y high bits	94	148	593	0.58	Green (y) = 10010100 (0.58)
1F	Blue x high bits	29	41	165	0.162	Blue (x) = 00101001 (0.162)
20	Blue y high bits	1C	28	112	0.11	Blue (y) = 00011100 (0.11)
21	White x high bits	50	80	320	0.313	White (x) = 01010000 (0.313)
22	White y high bits	54	84	336	0.329	White (y) = 01010100 (0.329)
23	Established timing 1	00	0		-	
24	Established timing 2	00	0		-	
25	Established timing 3	00	0		-	
26	Standard timing #1	01	1			Not Used
27		01	1			
28	Standard timing #2	01	1			Not Used
29		01	1			
2A	Standard timing #3	01	1			Not Used
2B		01	1			
2C	Standard timing #4	01	1			Not Used
2D		01	1			
2E	Standard timing #5	01	1			Not Used
2F		01	1			
30	Standard timing #6	01	1			Not Used
31		01	1			
32	Standard timing #7	01	1			Not Used
33		01	1			
34	Standard timing #8	01	1			Not Used
35		01	1			

36	Detailed timing/monitor descriptor #1	CE	206		76.3	76.3MHz Main clock
37		1D	29			
38		56	86		1366	Hor Active = 1366
39		F4	244		244	Hor Blanking = 244
3A		50	80		-	4 bits of Hor. Active + 4 bits of Hor. Blanking
3B		00	0		768	Ver Active = 768
3C		16	22		22	Ver Blanking = 22
3D		30	48		-	4 bits of Ver. Active + 4 bits of Ver. Blanking
3E		30	48		48	Hor Sync Offset = 48
3F		20	32		32	H Sync Pulse Width = 32
40		36	54		3	V sync Offset = 3 line
41		00	0		6	V Sync Pulse width : 6 line
42		00	0		256	Horizontal Image Size = 256 mm (Low 8 bits)
43		90	144		144	Vertical Image Size = 144 mm (Low 8 bits)
44	10	16		-	4 bits of Hor Image Size + 4 bits of Ver Image Size	
45	00	0		0	Hor Border (pixels)	
46	00	0		0	Vertical Border (Lines)	
47	1A	26			Refer to right table	
48	Detailed timing/monitor descriptor #2	E2	226		50.9	50.9MHz Main clock
49		13	19			
4A		56	86		1366	Hor Active = 1366
4B		F4	244		244	Hor Blanking = 244
4C		50	80		-	4 bits of Hor. Active + 4 bits of Hor. Blanking
4D		00	0		768	Ver Active = 768
4E		16	22		22	Ver Blanking = 22
4F		30	48		-	4 bits of Ver. Active + 4 bits of Ver. Blanking
50		30	48		48	Hor Sync Offset = 48
51		20	32		32	H Sync Pulse Width = 32
52		36	54		3	V sync Offset = 3 line
53		00	0		6	V Sync Pulse width : 6 line
54		00	0		256	Horizontal Image Size = 256 mm (Low 8 bits)
55		90	144		144	Vertical Image Size = 144 mm (Low 8 bits)
56	10	16		-	4 bits of Hor Image Size + 4 bits of Ver Image Size	
57	00	0		0	Hor Border (pixels)	
58	00	0		0	Vertical Border (Lines)	
59	00	0				
5A	Detailed timing/monitor descriptor #3	00	0			Nvidia nvDPS Lowest refresh rate that does not cause any visual/optical side effect
5B		00	0			
5C		00	0			
5D		00	0			
5E		00	0			
5F		00	0			
60		00	0			
61		00	0			
62		00	0			
63		00	0			
64		00	0			
65		00	0			
66		00	0			
67		00	0			
68	00	0				
69	00	0				
6A	00	0				
6B	00	0				



PRODUCT GROUP

REV

ISSUE DATE

TFT- LCD PRODUCT

O

SPEC. NUMBER

B4 NT116WHM-N10 Preliminary Product Specification  
Rev.0

PAGE  
35 OF 35

6C	Detailed timing/monitor descriptor #4	00	0		0	Detailed Timing Description #4
6D		00	0		0	Flag
6E		00	0		0	Reserved
6F		02	2		2	For Brightness Table and Power consumption
70		00	0		0	Flag
71		0A	10			PWM % [7:0] @ Step 0
72		3C	60			PWM % [7:0] @ Step 5
73		E2	226			PWM % [7:0] @ Step 10
74		0A	10			Nits [7:0] @ Step 0
75		3C	60			Nits [7:0] @ Step 5
76		6E	110			Nits [7:0] @ Step 10
77		15	21			Panel Electronics Power @32x32 Chess Pattern=850mW
78		0B	11			Backlight Power @60 nits=450mW
79		12	18			Backlight Power @Step 10=1474mW
7A		78	120			Nits @ 100% PWM Duty =240nit
7B		00	0		0	Flags
7C		00	0		0	Flags
7D	00	0		0	Flags	
7E	Extension flag	00	0			
7F	Checksum	9A	154	154	-	