



ELECTRONICS

Preliminary

TO :

DATE : June.04, 2001

SAMSUNG TFT-LCD
MODEL NO. : LTN150P3-L01

APPROVED BY : _____

CHECKED BY : _____

Notes :

This information described in the SPEC is preliminary and can be changed without prior notice

APPROVED BY : B. W. Lee

PREPARED BY : Application Engineering Team

SAMSUNG ELECTRONICS CO., LTD.

Doc.No.	LTN150P3-L01	Rev.No	04 - 001 - G - 010604	Page	1 /27
---------	--------------	--------	-----------------------	------	-------

CONTENTS

Revision History	----- (3)
General Description	----- (4)
1. Absolute Maximum Ratings	----- (5)
1.1 Absolute Ratings Of Environment	
1.2 Electrical Absolute Ratings	
2. Optical Characteristics	----- (7)
3. Electrical Characteristics	----- (10)
3.1 TFT LCD Module	
3.2 Back-light Unit	
4. Block Diagram	----- (13)
4.1 TFT LCD Module	
4.2 Back-light Unit	
5. Input Terminal Pin Assignment	----- (14)
5.1 Input Signal & Power	
5.2 LVDS Interface	
5.3 Back-light Unit	
5.4 Timing Diagrams of LVDS For Transmitting	
5.5 Input Signals, Basic Display Colors and Gray Scale of Each Color.	
5.6 Pixel format	
6. Interface Timing	----- (20)
6.1 Timing Parameters	
6.2 Timing Diagrams of interface Signal	
6.3 Power ON/OFF Sequence	
7. Outline Dimension	----- (22)
8. General Precautions	----- (23)
9. Packing	----- (25)
10. Marking & Others	----- (27)

Revision History

Preliminary

Date	Rev.No.	Page	Summary
May.10.2001	000		LTN150P3-L01 SXGA-Plus(1400X1050 pixel) Model was first issued
June.04.2001	001		Change the mechanical information(weight)

GENERAL DESCRIPTION

DESCRIPTION

LTN150P3-L01 is a color active matrix TFT (Thin Film Transistor) liquid crystal display (LCD) that uses amorphous silicon TFT as a switching devices. This model is composed of a TFT LCD panel, a driver circuit and a back-light system. The resolution of a 15.0" contains 1400 x 1050 pixels and can display up to 262,144 colors. 6 o'clock direction is the optimum viewing angle.

FEATURES

- Thin and light weight
- High contrast ratio
- SXGA-Plus (1400x1050 pixels) resolution
- Low power consumption
- DE (Data enable) only mode.
- LVDS Interface with 2 pixel / clock (2 channel)

APPLICATIONS

- Notebook PC and desktop monitors
- Display terminals for AV application products
- Monitors for Industrial machine
- If the usage of this product is not for PC application, but for others, please contact SEC.

GENERAL INFORMATION

ITEM	SPECIFICATION	UNIT	NOTE
Display area	304.5(H) x 228.375(V) (15.0" diagonal)	mm	
Driver element	a-Si TFT active matrix		
Display colors	262,144		
Number of pixel	1400 x 1050 (SXGA-Plus)	pixel	
Pixel arrangement	RGB vertical stripe		
Pixel pitch	0.2175(H) x 0.2175(V) (TYP.)	mm	
Display Mode	Normally white		
Surface treatment	HAZE (25), HARD-COATING 3H		

MECHANICAL INFORMATION

ITEM		MIN.	TYP.	MAX.	NOTE
Module size	Horizontal (H)	315.3	315.8	316.3	
	Vertical (V)	240.0	240.5	241.0	
	Depth (D)	5.4	5.7	(6.0)	
Weight		-	(550)	(570)	

1. ABSOLUTE MAXIMUM RATINGS

1.1 ABSOLUTE RATINGS OF ENVIRONMENT

ITEM	SYMBOL	MIN.	MAX.	UNIT	NOTE
Storage temperature	T _{STG}	-20	60	%°C	(1)
Operating temperature (Temperature of glass surface)	T _{OPR}	0	50	%°C	(1)
Shock (non-operating)	Snop	-	220	G	(2),(4)
Vibration (non-operating)	Vnop	-	1.5	G	(3),(4)

Note (1) Temperature and relative humidity range are shown in the figure below.
 90 % RH Max. (40 °C ≥ Ta)
 Maximum wet - bulb temperature at 39 °C or less. (Ta > 40%°C) No condensation.

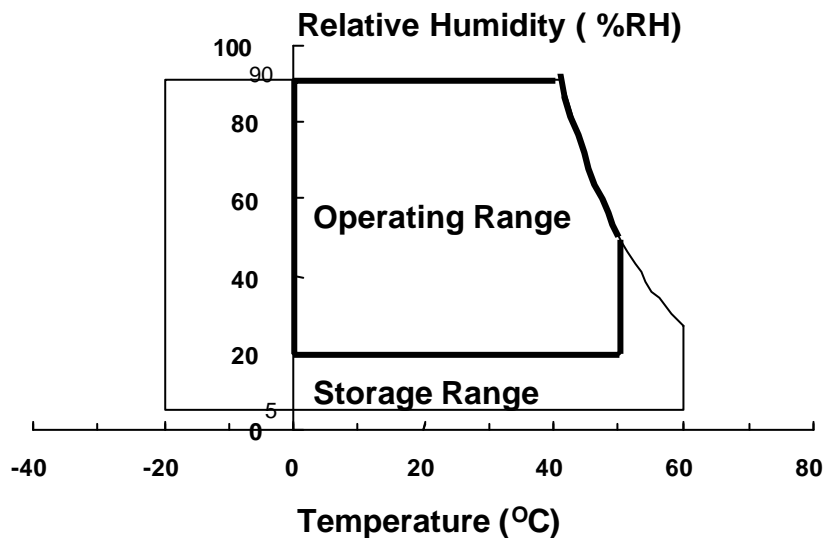

- (2) 2ms, half sine wave, one time for ± X, ± Y, ± Z.
- (3) 10 - 300 Hz, Sweep rate 10 min, 30min for X,Y,Z.
- (4) At testing Vibration and Shock, the fixture in holding the Module to be tested have to be hard and rigid enough so that the Module would not be twisted or bent by the fixture.

1.2 ELECTRICAL ABSOLUTE RATINGS

(1) TFT LCD MODULE

(V_{SS} = GND = 0 V)

ITEM	SYMBOL	MIN.	MAX.	UNIT	NOTE
Power Supply Voltage	V _{DD}	V _{SS} -0.3	4.0	V	(1)
Logic Input Voltage	V _{IN}	V _{SS} -0.3	V _{DD} +0.3	V	(1)

NOTE (1) Within Ta = 25 ± 2 °C

(2) BACK-LIGHT UNIT

Ta = 25 ± 2 °C

ITEM	SYMBOL	MIN.	MAX.	UNIT.	NOTE
Lamp current	I _L	(3.0)	(7.0)	mAms	(1)
Lamp frequency	F _L	(45)	(80)	KHz	(1)

NOTE (1) Permanent damage to the device may occur if maximum values are exceeded.
Functional operation should be restricted to the conditions described under Normal Operating Conditions.

2. OPTICAL CHARACTERISTICS

The following items are measured under stable conditions. The optical characteristics should be measured in a dark room or equivalent state with the methods shown in Note (5).

Measuring equipment : TOPCON BM-5A

* Ta = 25 ± 2°C , VDD=3.3V, fv= 60Hz, fDCLK=54MHz, IL = 6.0 mA

ITEM	SYMBOL	CONDITION	MIN.	TYP.	MAX.	UNIT	NOTE	
Contrast Ratio (5 Points)	CR	$\phi = 0,$ $\theta = 0$ Normal Viewing Angle	(180)	-	-		(1), (2), (5)	
Response Time at Ta	Rising		T _R	-	10	20	msec	(1), (3)
	Falling		T _F	-	30	50		
Average Luminance of White (5 Points)	Y _{L,AVE}			(120)	(150)	-	cd/m ²	(1), (4)
Color Chromaticity (CIE)	Red		R _X	TBD	TBD	TBD	Measured by PR 650	(1), (5)
			R _Y	TBD	TBD	TBD		
	Green		G _X	TBD	TBD	TBD		
			G _Y	TBD	TBD	TBD		
	Blue		B _X	TBD	TBD	TBD		
			B _Y	TBD	TBD	TBD		
	White	W _X	0.280	0.310	0.340			
		W _Y	0.310	0.340	0.370			
Viewing Angle	Hor.	θ_L	40	45	-	Degrees		
		θ_R	40	45	-			
	Ver.	ϕ_H	15	20	-			
		ϕ_L	30	40	-			
13 Points White Variation	δL		-	-	(2.0)		(6)	

Note 1) Definition of Viewing Angle : Viewing angle range($10 \leq C/R$)

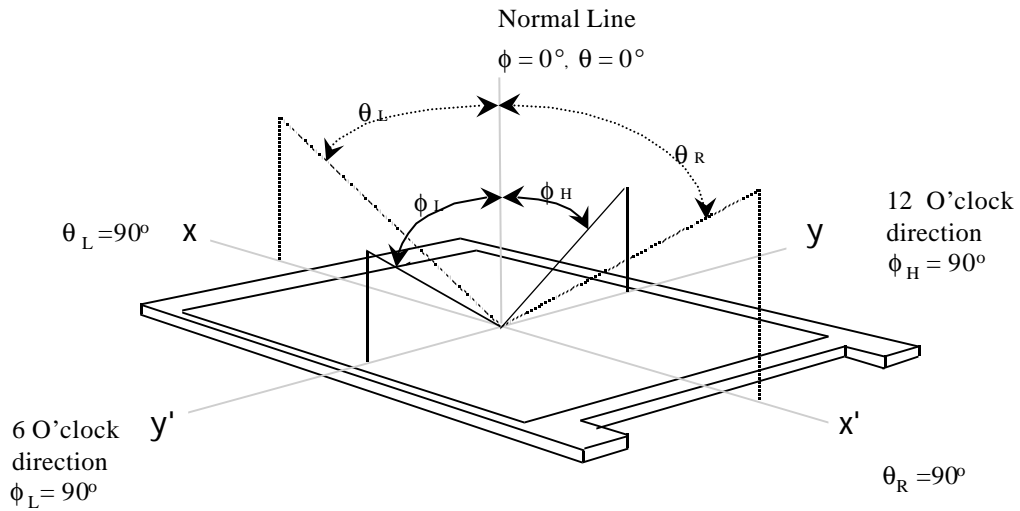

Note 2) Definition of Contrast Ratio (CR) : Ratio of gray max (Gmax) ,gray min (Gmin) at 5 points(4, 5, 7, 9, 10)

$$CR = \frac{CR(4) + CR(5) + CR(7) + CR(9) + CR(10)}{5}$$

POINTS : (4) , (5) , (7) , (9) , (10) at FIGURE OF NOTE 6)

Note 3) Definition of Response time :

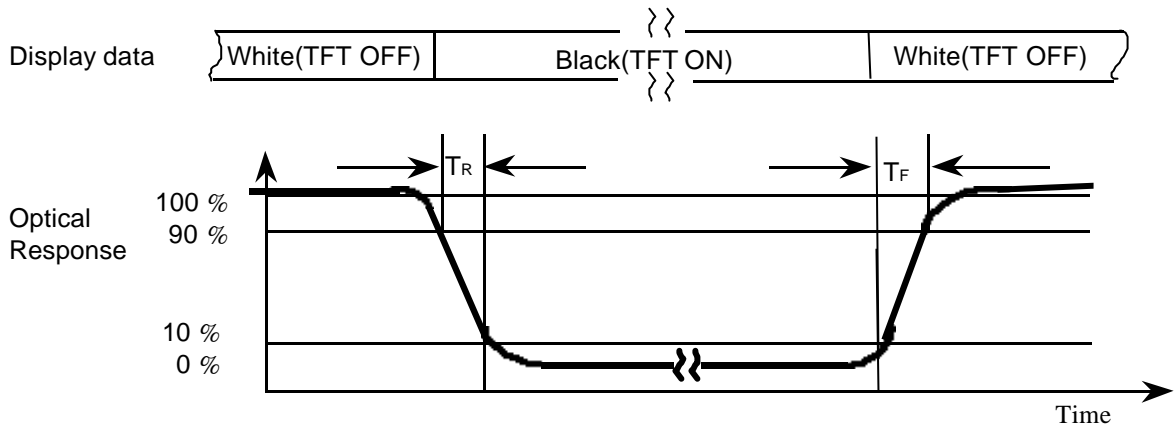

Note 4) Definition of Average Luminance of White : measure the luminance of white at 5 points.

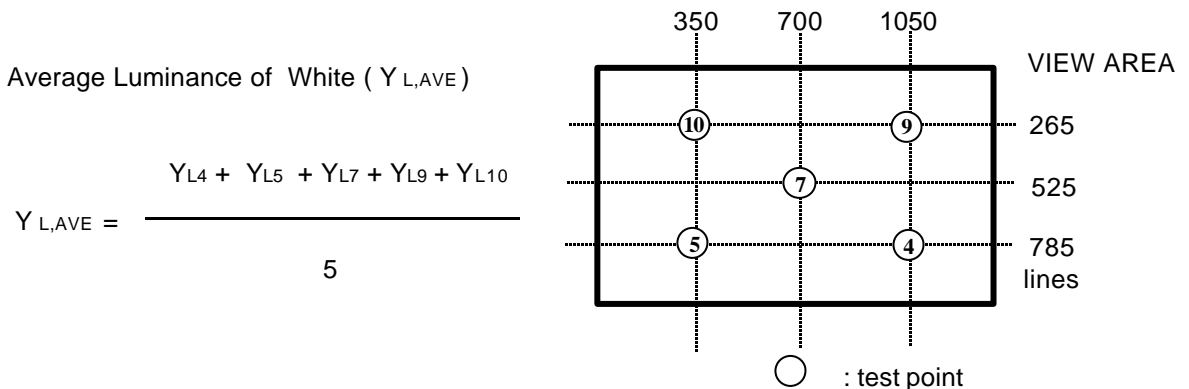

Note 5) After stabilizing and leaving the panel alone at a given temperature for 30 minutes, the measurement should be executed. Measurement should be executed in a stable, windless, and dark room. 30 minutes after lighting the back-light. This should be measured in the center of screen.
 Lamp current : 6.0 mA
 Environment condition : $T_a = 25 \pm 2 \text{ }^\circ\text{C}$

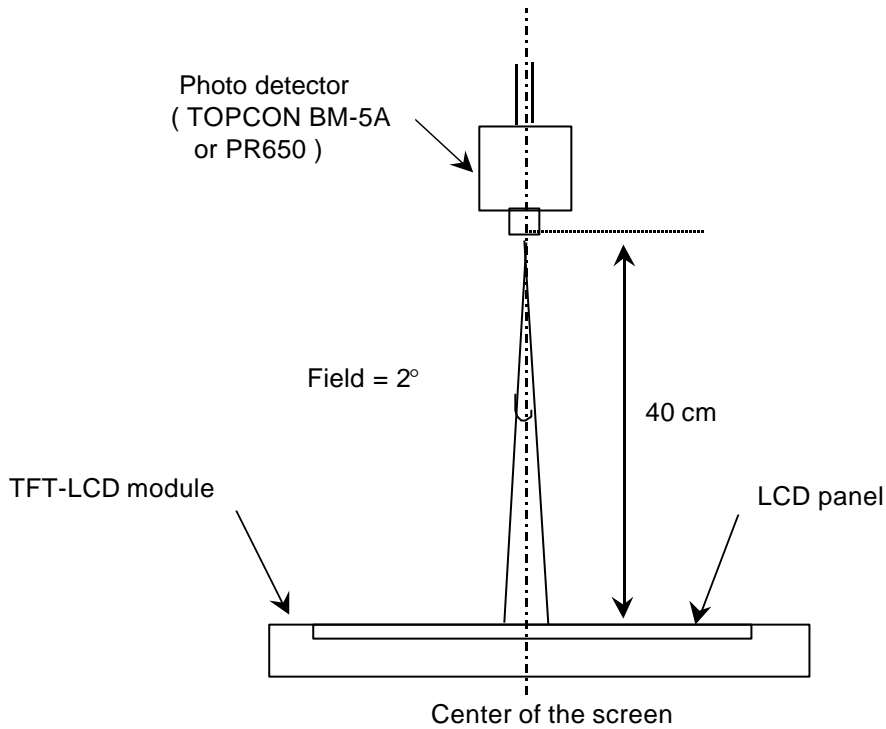

Optical characteristics measurement setup

Note 6) Definition of 13 points white variation (δ_w), CR variation(C_{VER}) [① ~ ⑬]

$$\delta_L = \frac{\text{Maximum luminance of 13 points}}{\text{Minimum luminance of 13 points}}$$

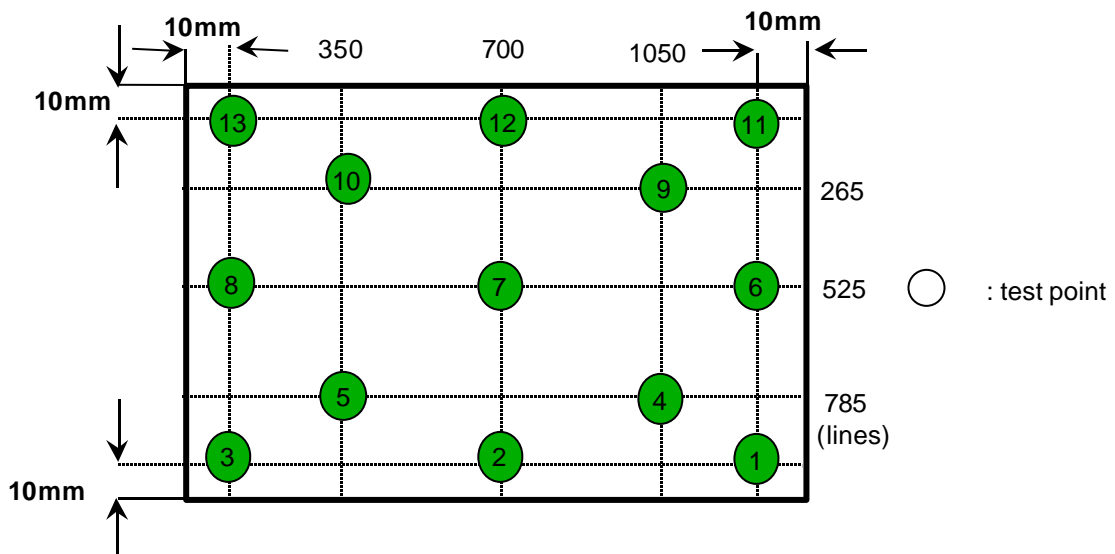

3. ELECTRICAL CHARACTERISTICS

3.1 TFT LCD MODULE

Ta = 25 ± 2%°C

ITEM		SYMBOL	MIN	TYP	MAX	UNIT	NOTE
Voltage of Power Supply		V _{DD}	3.0	3.3	3.6	V	
Differential Input Voltage for LVDS Receiver Threshold	High	V _{IH}	-	-	+100	mV	(1)
	Low	V _{IL}	-100	-	-	mV	
Vsync Frequency		f _v	-	60	-	Hz	
Hsync Frequency		f _H	-	63.98	-	KHz	
Main Frequency		f _{DCLK}	-	54	-	MHz	
Rush Current		I _{RUSH}	-	-	1.5	A	(4)
Current of Power Supply	White	I _{DD}	-	(470)	-	mA	(2),(3)
	Mosaic		-	(530)	-	mA	(2),(3)
	Dot (0/7)		-	(650)	(700)	mA	(2),(3)

- Note (1) Condition : V_{CM}=+1.2V(Common mode Voltage)
 (2) f_v=60Hz, f_{DCLK} =54MHZ, V_{dd} = 3.3V , DC Current.
 (3) Power dissipation check pattern

*a) White Pattern

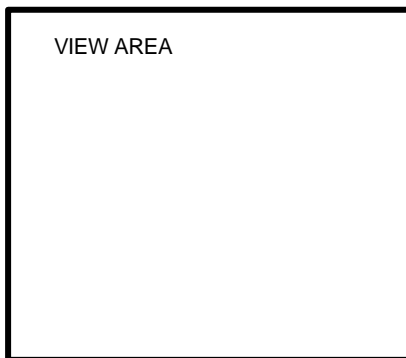

*b)Mosaic Pattern

Display Brightest Gray Level →
 Display Darkest Gray Level →

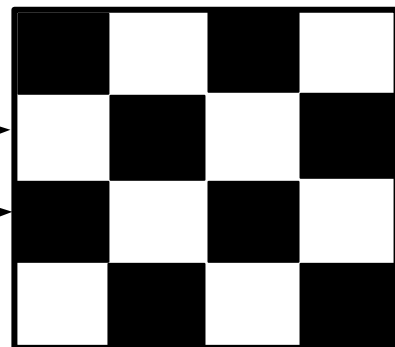

*c) Max Pattern (1 dot Inversion)

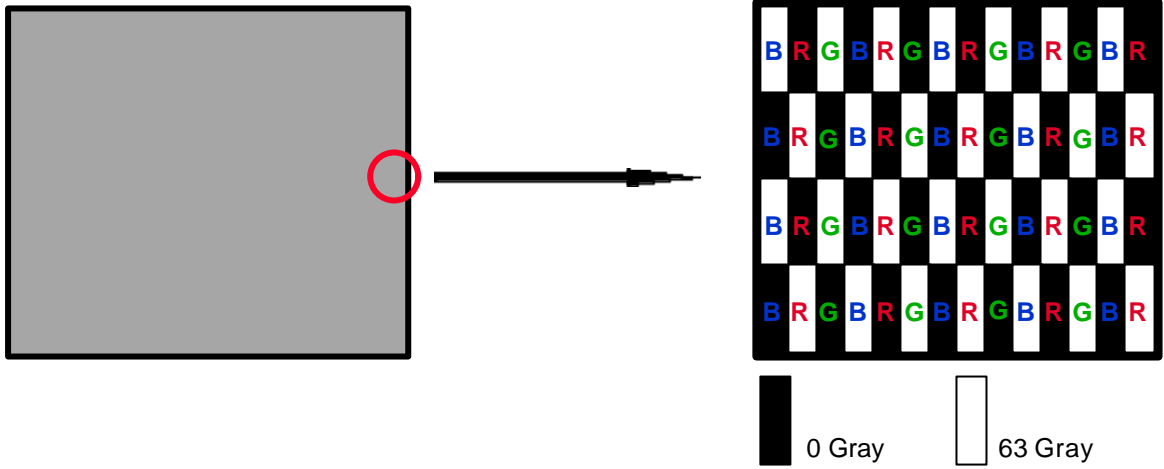

4) Rush current measurement condition

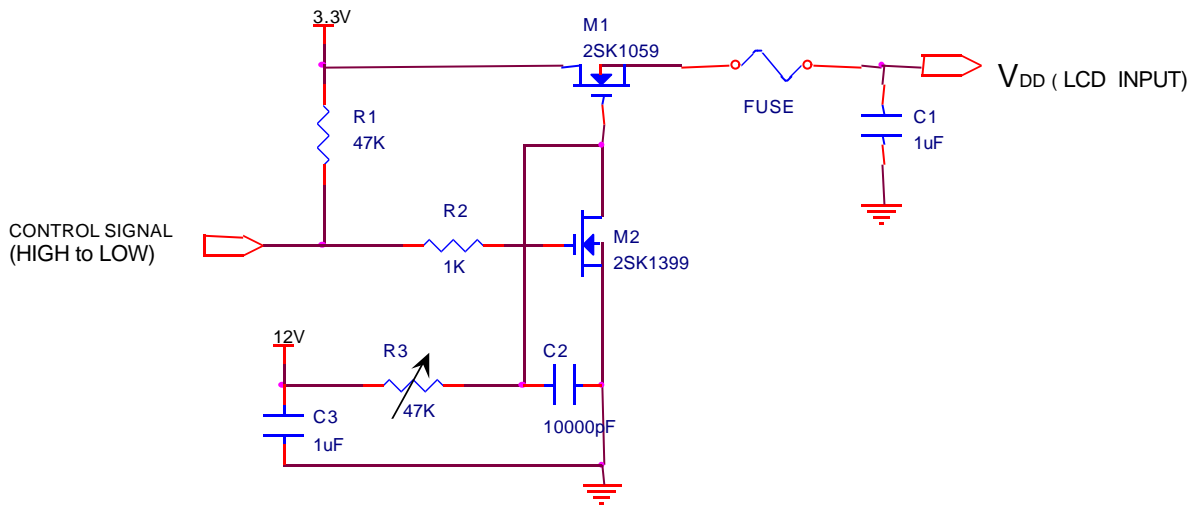

V_{DD} rising time is 470us

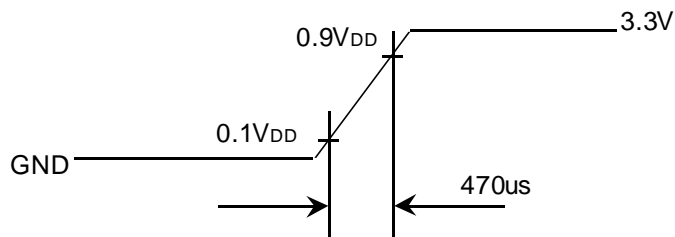

3.2 BACKLIGHT UNIT

The back-light system is an edge - lighting type with a single CCFT (Cold Cathode Fluorescent Tube).
The characteristics of a single lamp are shown in the following tables.

INVERTER : SEM SIC-130T

Ta = 25 ± 2°C

ITEM	SYMB	MIN	TYP	MAX	UNIT	NOTE
Lamp Current	I _L	(3.0)	(5.0)	(6.0)	mArms	(1)
Lamp Voltage	V _L	-	(690)	-	Vrms	
Frequency	f _L	(45)	(60)	(65)	KHz	(2)
Power Consumption	P _L	-	(3.45)	-	W	(3)
Operating Life Time	H _r	(10,000)	-	-	Hour	(4)
Startup Voltage	V _s	-	-	(1200) (25°C)	Vrms	(5)
				(1500) (0°C)		

Note) The waveform of the inverter output voltage must be area symmetric and the design of the inverter must have specifications for the modularized lamp.

The performance of the back-light, for example life time or brightness, is much influenced by the characteristics of the DC-AC inverter for the lamp. So all the parameters of an inverter should be carefully designed so as not to produce too much leakage current from high-voltage output of the inverter. When you design or order the inverter, please make sure that a poor lighting caused by the mismatch of the back-light and the inverter(miss lighting, flicker, etc.) never occur. When you confirm it, the module should be operated in the same condition as it is installed in your instrument.

Note (1) Lamp current is measured with a high frequency current meter as shown below.

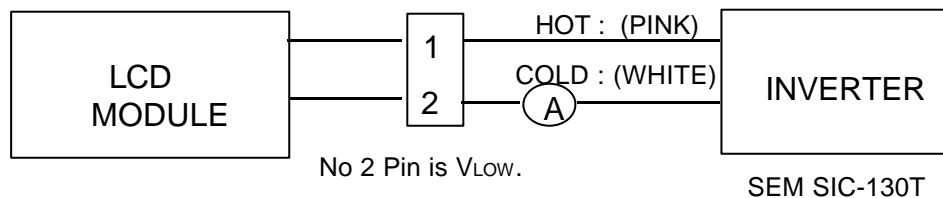

(2) Lamp frequency may produce interference with horizontal synchronous frequency and this may cause line flow on the display. Therefore lamp frequency should be detached from the horizontal synchronous frequency and its harmonics as far as possible in order to avoid interference.

(3) refer to I_L X V_L to calculate.

(4) Life time (Hr) of a lamp can be defined as the time in which it continues to operate under the condition Ta = 25 ± 2°C and I_L = 6.0 mArms until one of the following event occurs.

1. When the brightness becomes 50% or lower than it's original.
2. When the Effective ignition length becomes 80% or lower than it's original value.
(Effective ignition length is defined as an area that has less than 70% brightness compared to the brightness in the center point.)

(5) The voltage above this value should be applied to the lamp for more than 1 second to startup. Otherwise the lamp may not be turned on.

4. BLOCK DIAGRAM

4.1 TFT LCD MODULE

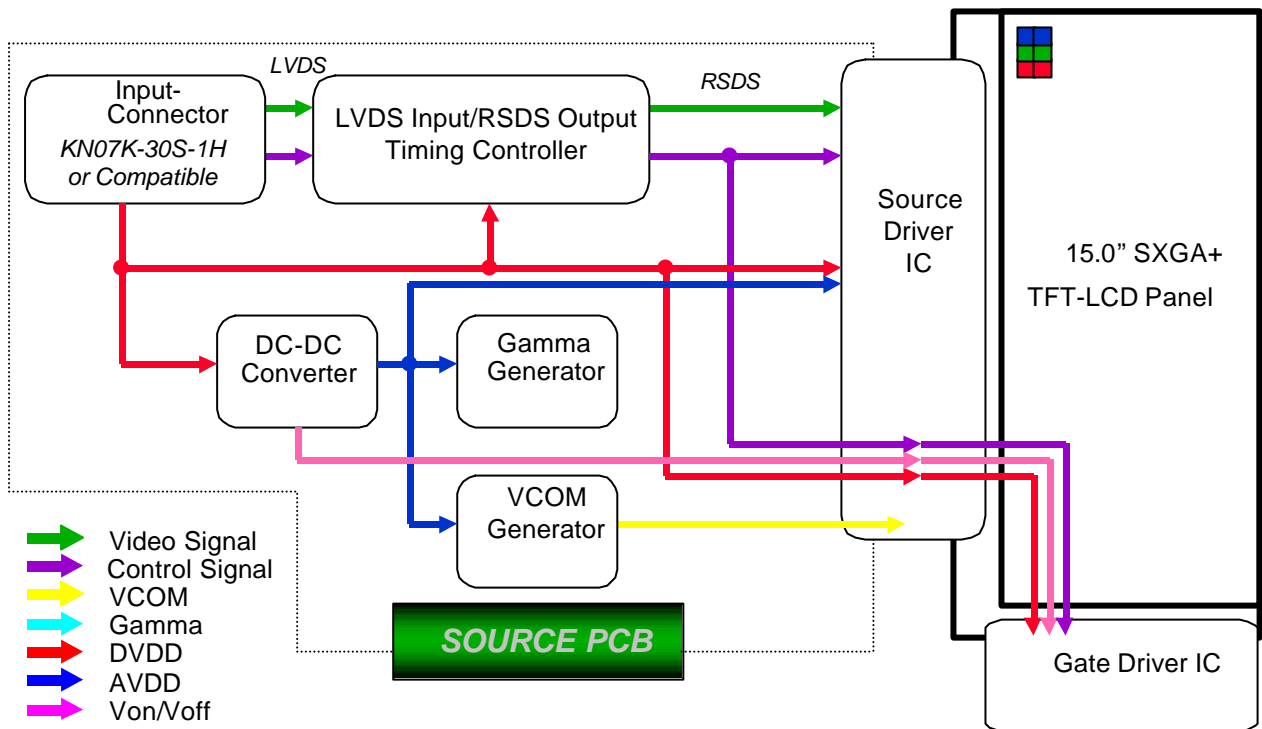

4.2 BACKLIGHT UNIT

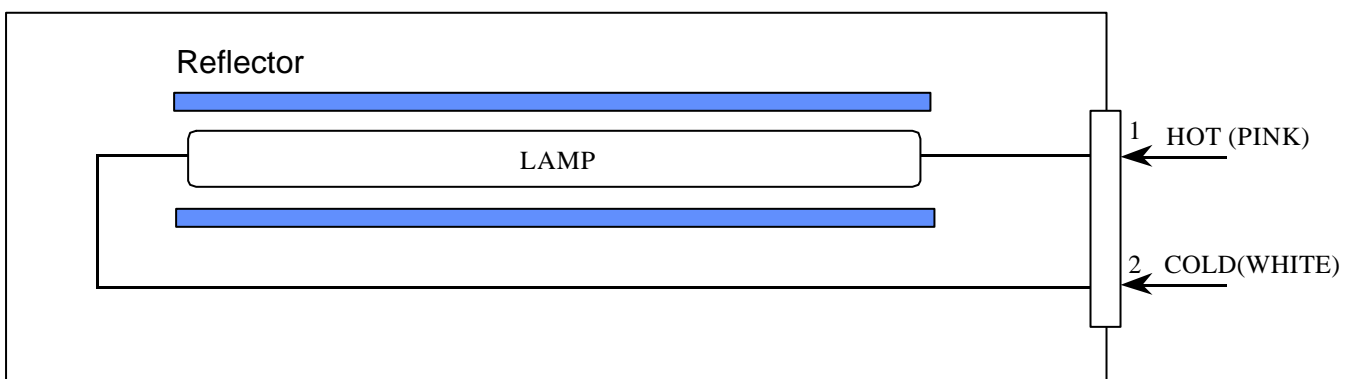

Note) The output of the inverter may change according to the material of the reflector.

5. INPUT TERMINAL PIN ASSIGNMENT

5.1. Input Signal & Power (LVDS, Connector : HIROSE, KN07K-30S-1H or Compatible)

PIN NO	SYMBOL	FUNCTION	POLARITY	REMARK
1	GND 1	GROUND		
2	VDD 1	POWER SUPPLY +3.3V		
3	VDD 2	POWER SUPPLY +3.3V		
4	N.C	Reserved		
5	N.C	Reserved		
6	N.C	Reserved		
7	N.C	Reserved		
8	O_RxIN0-	LVDS Differential Data INPUT (Odd channel 0)	Negative	
9	O_RxIN0+	LVDS Differential Data INPUT (Odd channel 0)	Positive	
10	GND 6	GROUND		
11	O_RxIN1-	LVDS Differential Data INPUT (Odd channel 1)	Negative	
12	O_RxIN1+	LVDS Differential Data INPUT (Odd channel 1)	Positive	
13	GND 7	GROUND		
14	O_RxIN2-	LVDS Differential Data INPUT (Odd channel 2)	Negative	
15	O_RxIN2+	LVDS Differential Data INPUT (Odd channel 2)	Positive	
16	GND 8	GROUND		
17	O_RxCLK-	LVDS Differential Data INPUT (Odd Clock)	Negative	
18	O_RxCLK+	LVDS Differential Data INPUT (Odd Clock)	Positive	
19	GND 9	GROUND		
20	E_RxIN0-	LVDS Differential Data INPUT (Even channel 0)	Negative	
21	E_RxIN0+	LVDS Differential Data INPUT (Even channel 0)	Positive	
22	GND 10	GROUND		
23	E_RxIN1-	LVDS Differential Data INPUT (Even channel 1)	Negative	
24	E_RxIN1+	LVDS Differential Data INPUT (Even channel 1)	Positive	
25	GND 11	GROUND		
26	E_RxIN2-	LVDS Differential Data INPUT (Even channel 2)	Negative	
27	E_RxIN2+	LVDS Differential Data INPUT (Even channel 2)	Positive	
28	GND 12	GROUND		
29	E_RxCLK-	LVDS Differential Data INPUT (Even Clock)	Negative	
30	E_RxCLK+	LVDS Differential Data INPUT (Even Clock)	Positive	

5.2 LVDS Interface : Transmitter DS90CF363 or Compatible

LVDS for Odd pixel

Pin No.	Name	RGB Signal	Pin No.	Name	RGB Signal
44	TxIN0	RO0	12	TxIN11	GO5
45	TxIN1	RO1	13	TxIN12	BO0
47	TxIN2	RO2	15	TxIN13	BO1
48	TxIN3	RO3	16	TxIN14	BO2
1	TxIN4	RO4	18	TxIN15	BO3
3	TxIN5	RO5	19	TxIN16	BO4
4	TxIN6	GO0	20	TxIN17	BO5
6	TxIN7	GO1	22	TxIN18	Hsync
7	TxIN8	GO2	23	TxIN19	Vsync
9	TxIN9	GO3	25	TxIN20	DE
10	TxIN10	GO4	26	TxCLK IN	Clock

LVDS for Even pixel

Pin No.	Name	RGB Signal	Pin No.	Name	RGB Signal
44	TxIN0	RE0	12	TxIN11	GE5
45	TxIN1	RE1	13	TxIN12	BE0
47	TxIN2	RE2	15	TxIN13	BE1
48	TxIN3	RE3	16	TxIN14	BE2
1	TxIN4	RE4	18	TxIN15	BE3
3	TxIN5	RE5	19	TxIN16	BE4
4	TxIN6	GE0	20	TxIN17	BE5
6	TxIN7	GE1	22	TxIN18	Hsync
7	TxIN8	GE2	23	TxIN19	Vsync
9	TxIN9	GE3	25	TxIN20	DE
10	TxIN10	GE4	26	TxCLK IN	Clock

Flat Link Interface

HIROSE, KN07K-30S-1H

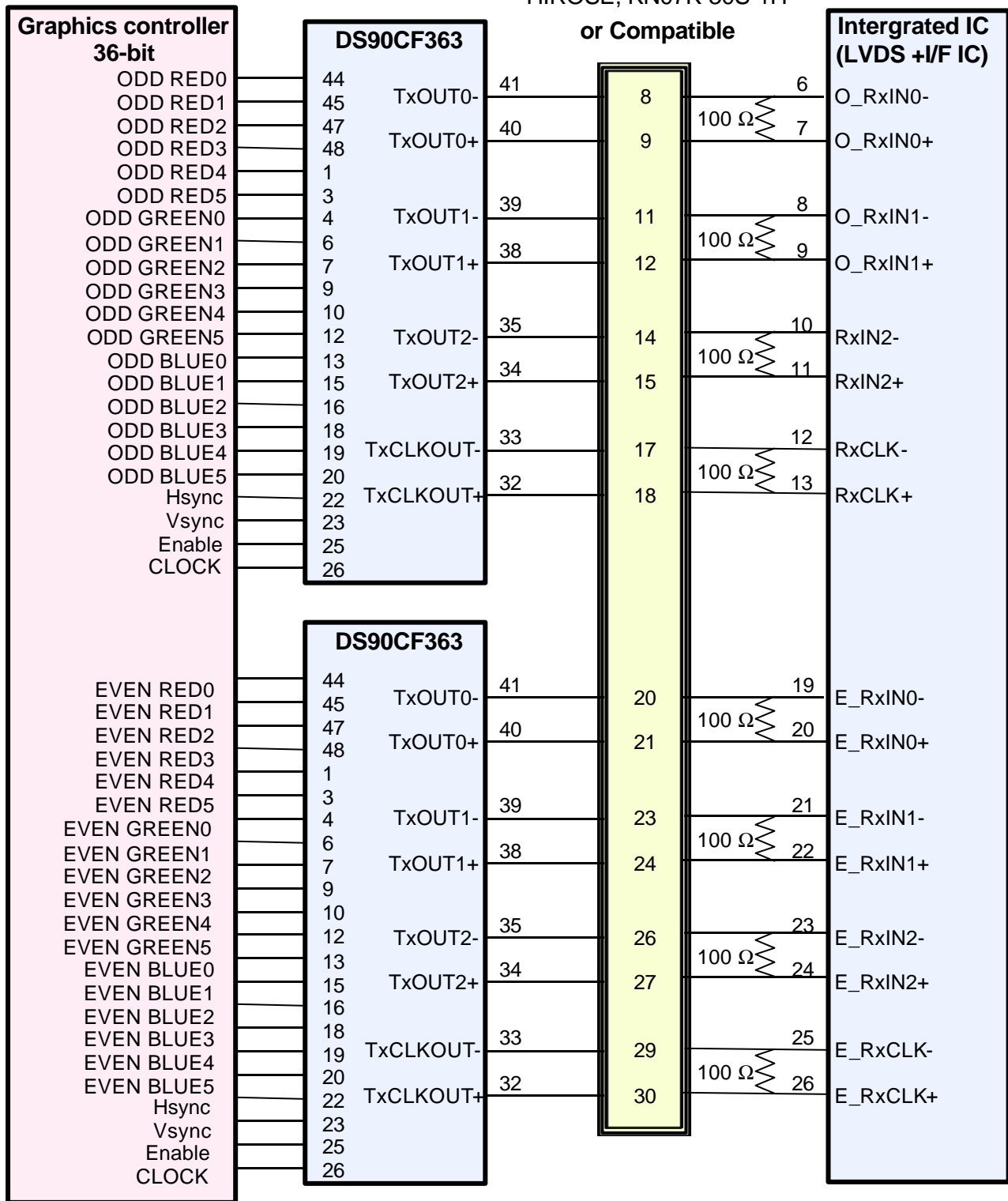

Note : The LCD Module uses a 100ohm resistor between positive and negative lines of each receiver input.

5.3 BACK LIGHT UNIT

Connector : JST BHSR - 02VS -1
 Mating Connector : JST SM02B-BHSS-1

Pin NO.	Symbol	Color	Function
1	HOT	PINK	High Voltage
2	COLD	WHITE	Low Voltage

5.4 Timing Diagrams of LVDS For Transmission

LVDS Receiver : DS90CF364A or Compatible

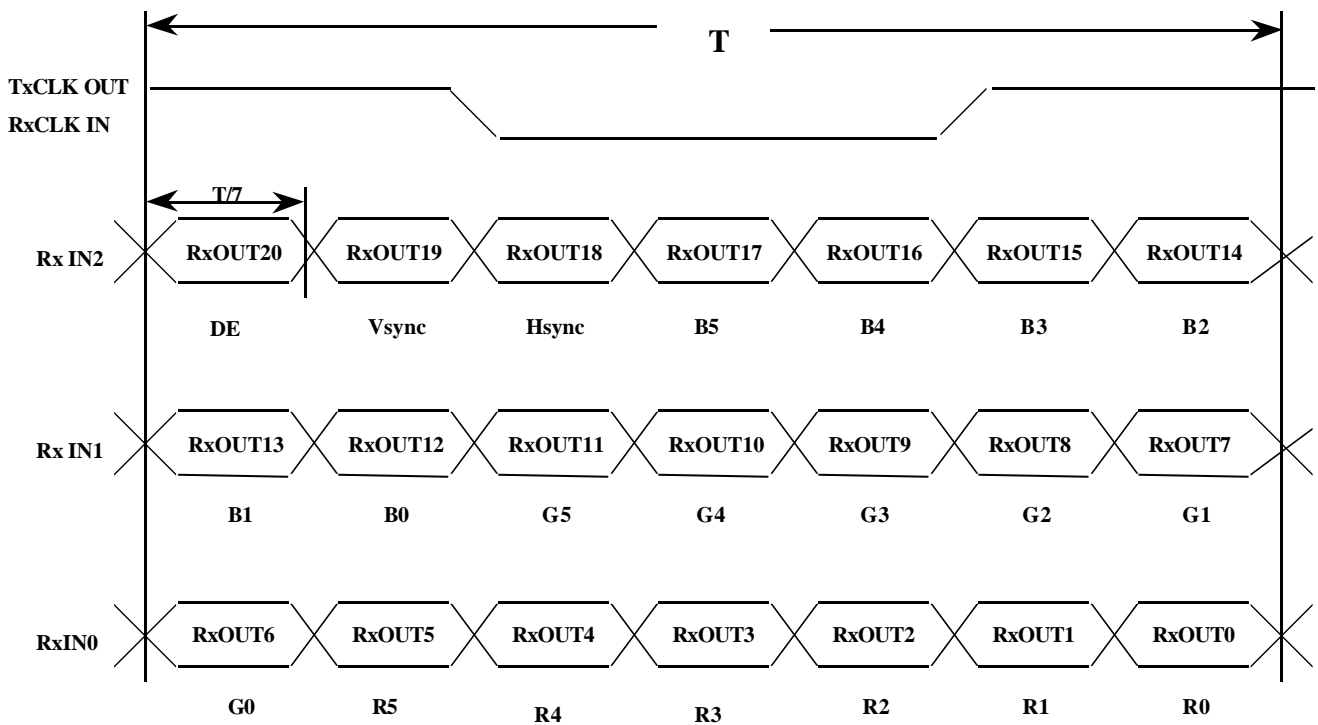

5.5 Input Signal, Basic Display Colors and Gray Scale of Each Colors

COLOR	DISPLAY	DATA SIGNAL															GRAY SCALE LEVEL			
		RED					GREEN					BLUE								
		R0	R1	R2	R3	R4	R5	G0	G1	G2	G3	G4	G5	B0	B1	B2		B3	B4	B5
BASIC COLOR	BLACK	0	0	0	0	0	0	0	0	0	0	0	0	0	0	0	0	0	0	-
	BLUE	0	0	0	0	0	0	0	0	0	0	0	0	1	1	1	1	1	1	-
	GREEN	0	0	0	0	0	0	1	1	1	1	1	1	0	0	0	0	0	0	-
	CYAN	0	0	0	0	0	0	1	1	1	1	1	1	1	1	1	1	1	1	-
	RED	1	1	1	1	1	1	0	0	0	0	0	0	0	0	0	0	0	0	-
	MAGENTA	1	1	1	1	1	1	0	0	0	0	0	0	1	1	1	1	1	1	-
	YELLOW	1	1	1	1	1	1	1	1	1	1	1	1	0	0	0	0	0	0	-
	WHITE	1	1	1	1	1	1	1	1	1	1	1	1	1	1	1	1	1	1	-
GRAY SCALE OF RED	BLACK	0	0	0	0	0	0	0	0	0	0	0	0	0	0	0	0	0	0	R0
	DARK	1	0	0	0	0	0	0	0	0	0	0	0	0	0	0	0	0	0	R1
		0	1	0	0	0	0	0	0	0	0	0	0	0	0	0	0	0	0	R2
		:	:	:	:	:	:	:	:	:	:	:	:	:	:	:	:	:	:	R3~R60
	:	:	:	:	:	:	:	:	:	:	:	:	:	:	:	:	:	:		
	LIGHT	1	0	1	1	1	1	0	0	0	0	0	0	0	0	0	0	0	0	R61
		0	1	1	1	1	1	0	0	0	0	0	0	0	0	0	0	0	0	R62
	RED	1	1	1	1	1	1	0	0	0	0	0	0	0	0	0	0	0	0	R63
GRAY SCALE OF GREEN	BLACK	0	0	0	0	0	0	0	0	0	0	0	0	0	0	0	0	0	0	G0
	DARK	0	0	0	0	0	0	1	0	0	0	0	0	0	0	0	0	0	0	G1
		0	0	0	0	0	0	0	1	0	0	0	0	0	0	0	0	0	0	G2
		:	:	:	:	:	:	:	:	:	:	:	:	:	:	:	:	:	:	G3~G60
	:	:	:	:	:	:	:	:	:	:	:	:	:	:	:	:	:	:		
	LIGHT	0	0	0	0	0	0	1	0	1	1	1	1	0	0	0	0	0	0	G61
		0	0	0	0	0	0	0	1	1	1	1	1	0	0	0	0	0	0	G62
	GREEN	0	0	0	0	0	0	1	1	1	1	1	1	0	0	0	0	0	0	G63
GRAY SCALE OF BLUE	BLACK	0	0	0	0	0	0	0	0	0	0	0	0	0	0	0	0	0	0	B0
	DARK	0	0	0	0	0	0	0	0	0	0	0	0	1	0	0	0	0	0	B1
		0	0	0	0	0	0	0	0	0	0	0	0	0	1	0	0	0	0	B2
		:	:	:	:	:	:	:	:	:	:	:	:	:	:	:	:	:	:	B3~B60
	:	:	:	:	:	:	:	:	:	:	:	:	:	:	:	:	:	:		
	LIGHT	0	0	0	0	0	0	0	0	0	0	0	0	1	0	1	1	1	1	B61
		0	0	0	0	0	0	0	0	0	0	0	0	0	1	1	1	1	1	B62
	BLUE	0	0	0	0	0	0	0	0	0	0	0	0	1	1	1	1	1	1	B63

Note

(1) Definition of Gray : Rn : Red Gray, Gn : Green Gray, Bn : Blue Gray (n = Gray level)

(2) Input Signal : 0 = Low level voltage, 1 = High level voltage

5.6 PIXEL FORMAT

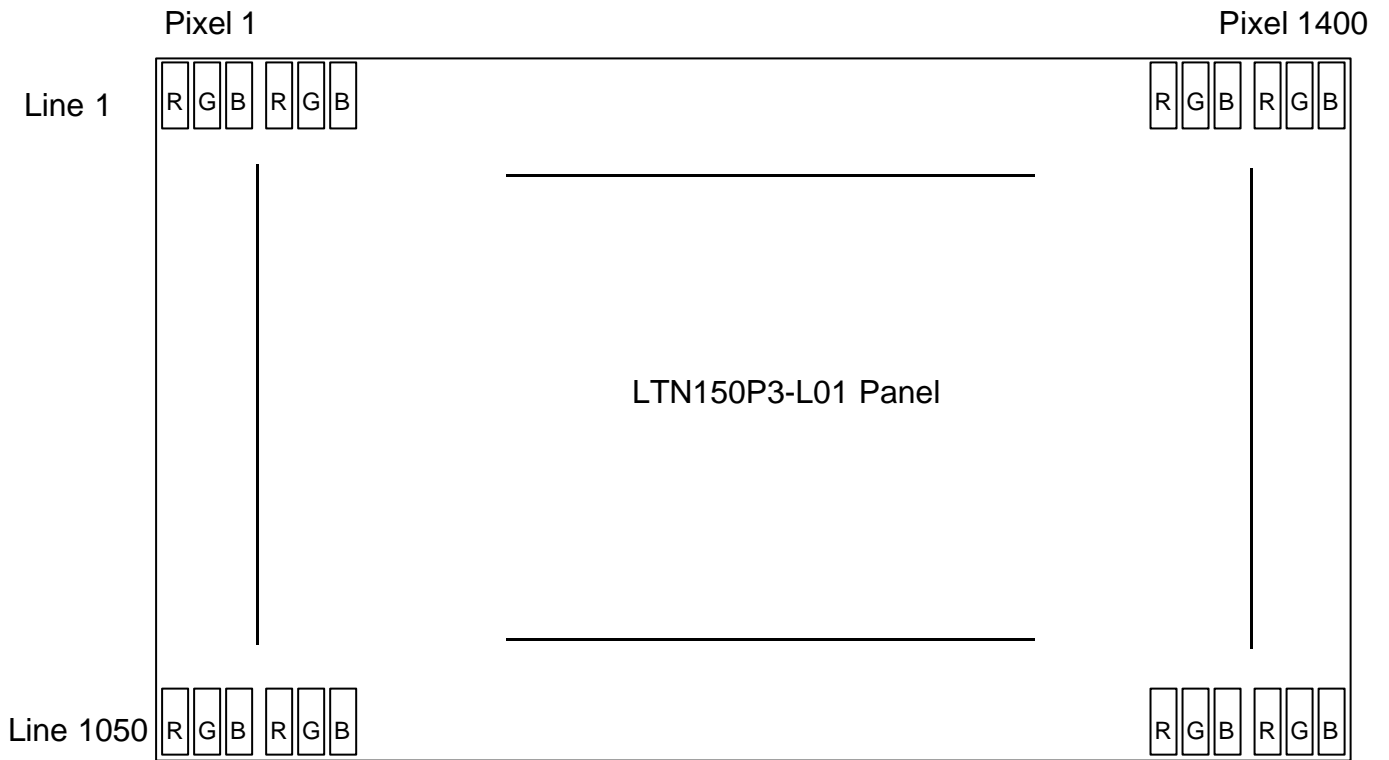

6. INTERFACE TIMING

6.1 Timing Parameters

Signal	Item	Symbol	MIN	TYP	MAX	Unit	Note
Frame Frequency	Cycle	T_v	-	1066	-	lines	
Vertical Active Display Term	Display Period	T_{vD}	-	1050	-	lines	
One Line Scanning Time	Cycle	T_H	-	844	-	clocks	(1)
Horizontal Active Display Term	Display Period	T_{HD}	-	700	-	clocks	

6.2 Timing diagrams of interface signal

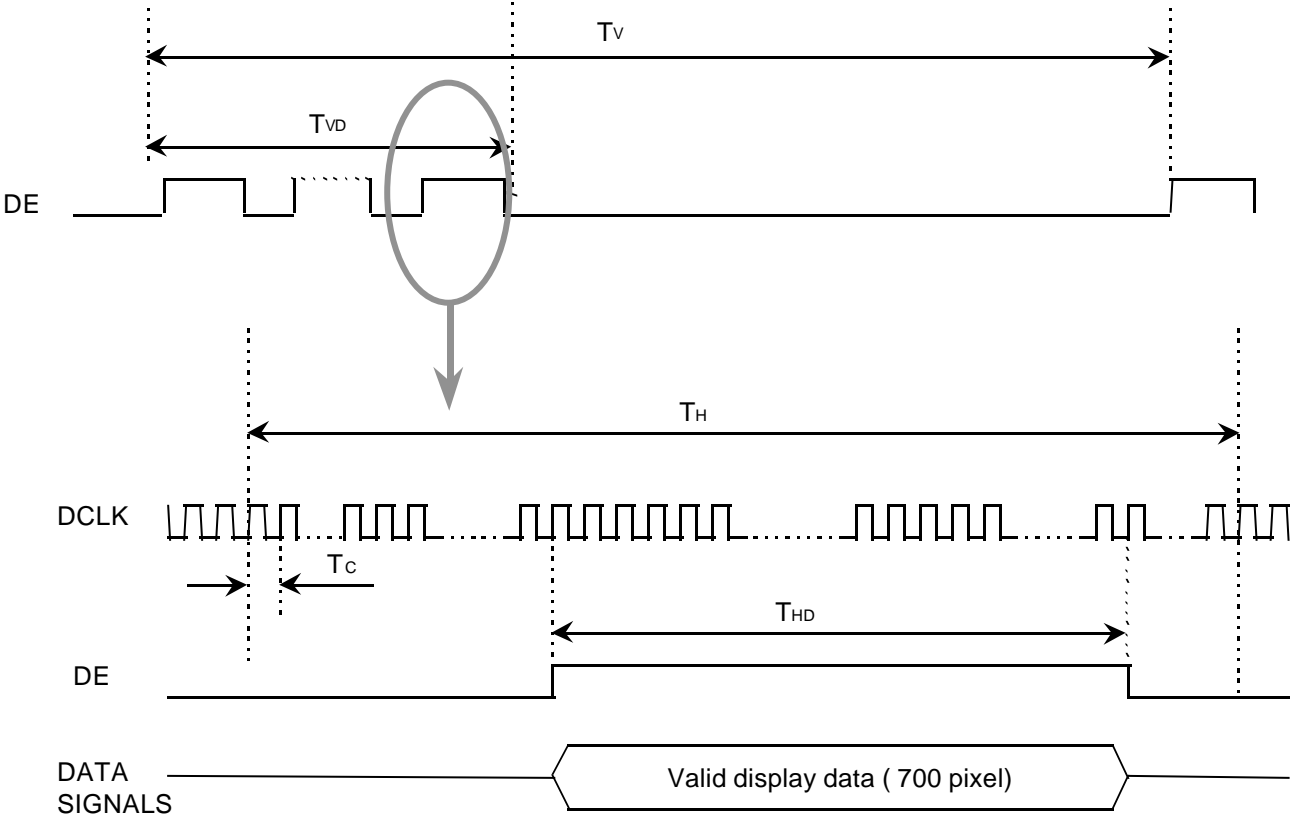

6.3 Power ON/OFF Sequence

: To prevent a latch-up or DC operation of the LCD module, the power on/off sequence should be as the diagram below.

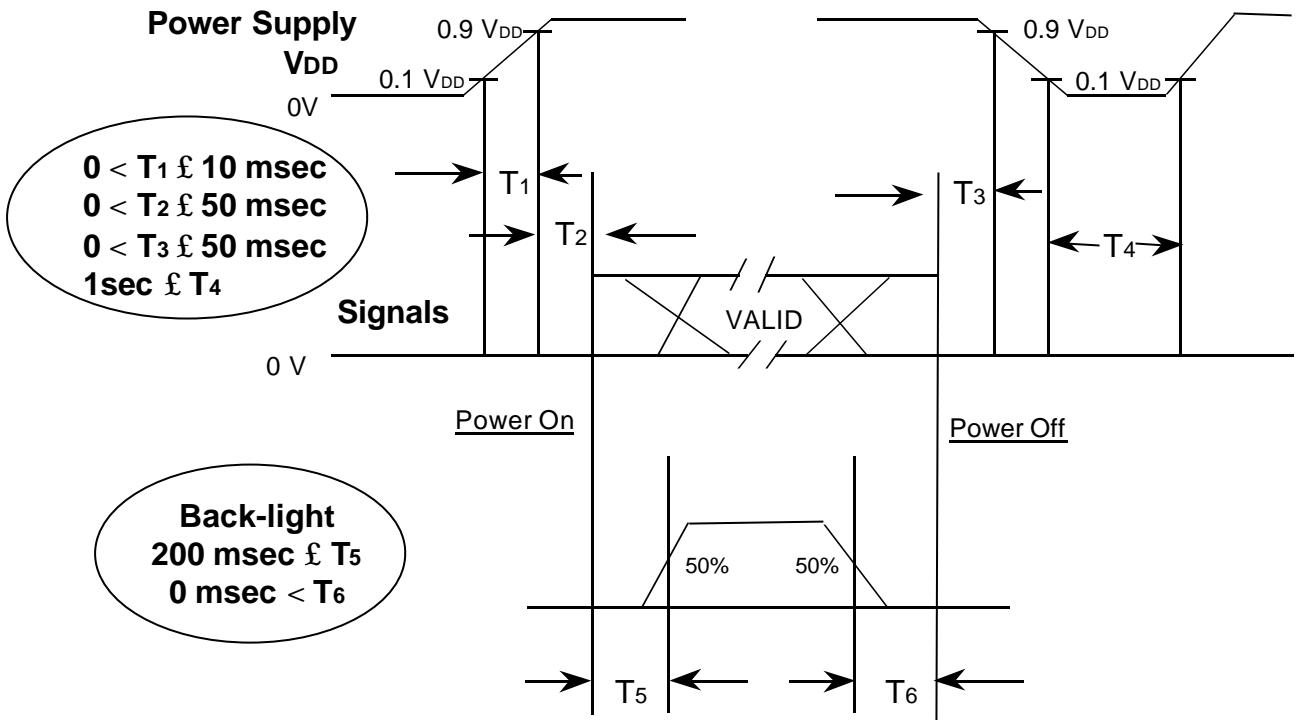

Power ON/OFF Sequence

- T1 : Vdd rising time from 10% to 90%
- T2 : The time from Vdd to valid data at power ON.
- T3 : The time from valid data off to Vdd off at power Off.
- T4 : Vdd off time for Windows restart
- T5 : The time from valid data to B/L enable at power ON.
- T6 : The time from valid data off to B/L disable at power Off.

NOTE.

- (1) The supply voltage of the external system for the module input should be the same as the definition of V_{DD}.
- (2) Apply the lamp voltage within the LCD operation range. When the back-light turns on before the LCD operation or the LCD turns off before the back-light turns off, the display may momentarily become white.
- (3) In case of V_{DD} = off level, please keep the level of input signals on the low or keep a high impedance.
- (4) T₄ should be measured after the module has been fully discharged between power off and on period.
- (5) Interface signal shall not be kept at high impedance when the power is on.

7. Outline Dimension

Preliminary

8. GENERAL PRECAUTIONS

Preliminary

1. Handling

- (a) When the module is assembled, It should be attached to the system firmly using every mounting holes. Be careful not to twist and bend the modules.
- (b) Refrain from strong mechanical shock and / or any force to the module. In addition to damage, this may cause improper operation or damage to the module and CCFT back-light.
- (c) Note that polarizers are very fragile and could be easily damaged. Do not press or scratch the surface harder than a HB pencil lead.
- (d) Wipe off water droplets or oil immediately. If you leave the droplets for a long time, Staining and discoloration may occur.
- (e) If the surface of the polarizer is dirty, clean it using some absorbent cotton or soft cloth.
- (f) The desirable cleaners are water, IPA(Isopropyl Alcohol) or Hexane. Do not use Ketone type materials(ex. Acetone), Ethyl alcohol, Toluene, Ethyl acid or Methyl chloride. It might permanent damage to the polarizer due to chemical reaction.
- (g) If the liquid crystal material leaks from the panel, it should be kept away from the eyes or mouth. In case of contact with hands, legs or clothes, it must be washed away thoroughly with soap.
- (h) Protect the module from static, it may cause damage to the C-MOS Gate Array IC.
- (i) Use fingerstalls with soft gloves in order to keep display clean during the incoming inspection and assembly process.
- (j) Do not disassemble the module.
- (k) Do not pull or fold the lamp wire.
- (l) Do not adjust the variable resistor which is located on the back side.
- (m) Protection film for polarizer on the module shall be slowly peeled off just before use so that the electrostatic charge can be minimized.
- (n) Pins of I/F connector shall not be touched directly with bare hands.

2. STORAGE

- (a) Do not leave the module in high temperature, and high humidity for a long time.
It is highly recommended to store the module with temperature from 0 to 35 °C and relative humidity of less than 70%.
- (b) Do not store the TFT-LCD module in direct sunlight.
- (c) The module shall be stored in a dark place. It is prohibited to apply sunlight or fluorescent light during the store.

3. OPERATION

- (a) Do not connect, disconnect the module in the “ Power On” condition.
- (b) Power supply should always be turned on/off by following item 6.3 “ Power on/off sequence “.
- (c) Module has high frequency circuits. Sufficient suppression to the electromagnetic interference shall be done by system manufacturers. Grounding and shielding methods may be important to minimize the interference.
- (d) The cable between the back-light connector and its inverter power supply shall be a minimized length and be connected directly . The longer cable between the back-light and the inverter may cause lower luminance of lamp(CCFT) and may require higher startup voltage(Vs).

4. OTHERS

- (a) Ultra-violet ray filter is necessary for outdoor operation.
- (b) Avoid condensation of water. It may result in improper operation or disconnection of electrode.
- (c) Do not exceed the absolute maximum rating value. (the supply voltage variation, input voltage variation, variation in part contents and environmental temperature, so on)
Otherwise the module may be damaged.
- (d) If the module displays the same pattern continuously for a long period of time, it can be the situation when the image “sticks” to the screen.
- (e) This module has its circuitry PCB's on the rear side and should be handled carefully in order not to be stressed.

9. Packing

9.1 CARTON(Internal Packing)

(1) Packing Form

Corrugated fiberboard box and corrugated foam as shock absorber

(2)Packing Method

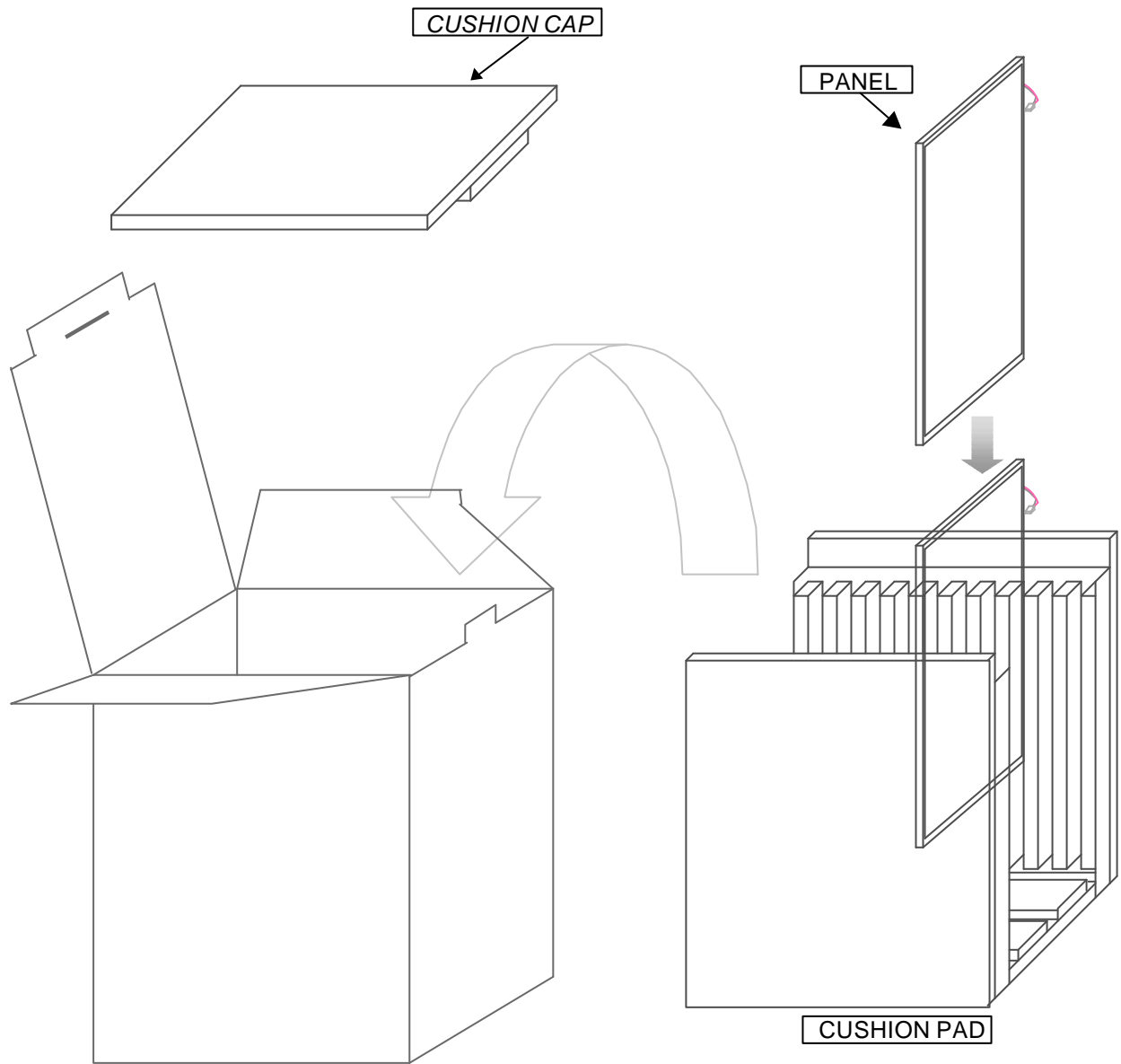

Note (1)Acceptance number of piling : 10 sets

(2)Carton size : 380(W) X 324(D) X 410(H)

(3)Packing Material

NO.	Parts name	Quantity
1.	Static electric protective sack	10 pcs
2.	Packing case (inner box) include shock absorber	1 set
3.	Pictorial marking	2 pics
4.	Carton	1 set

10. Marking & Others

A nameplate bearing followed by is affixed to a shipped product at the specified location on each product.

- (1)Parts number : LTN150P3-L01
- (2)Revision : One letter
- (3)Control Code : One letter
- (4)Lot number : 2 1 0 A ~~XXX-XX-XX~~

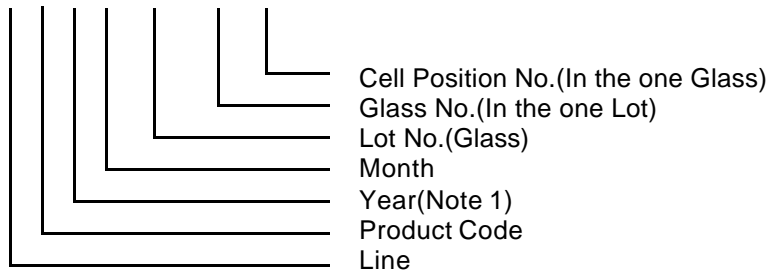

NOTE 1). This code indicating year is omitted in the products of KIHENG site.

(5) Nameplate Indication

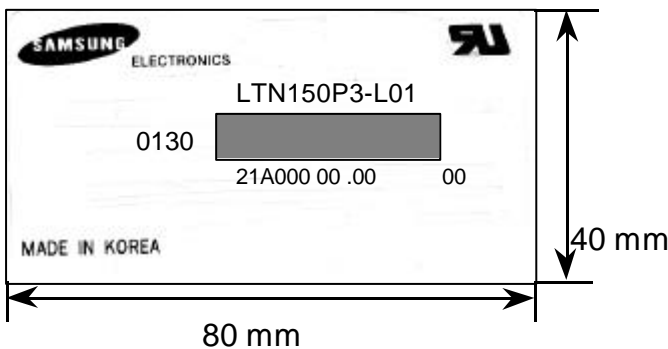

LTN... : Parts name
21A... : Lot number
0130 : Inspected work week

High voltage caution mark

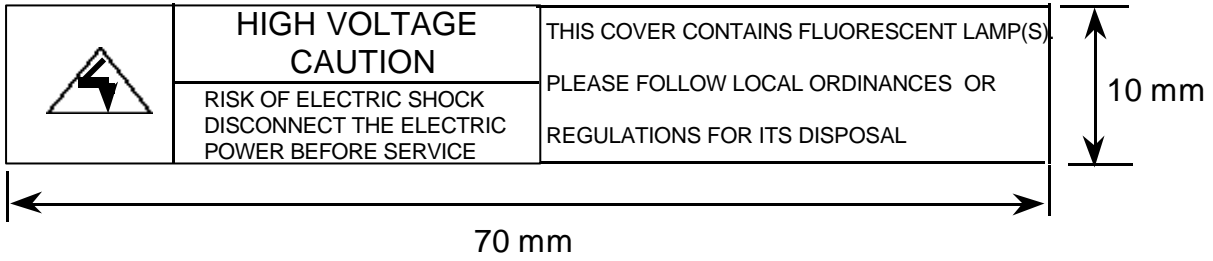

(6) Packing box attach

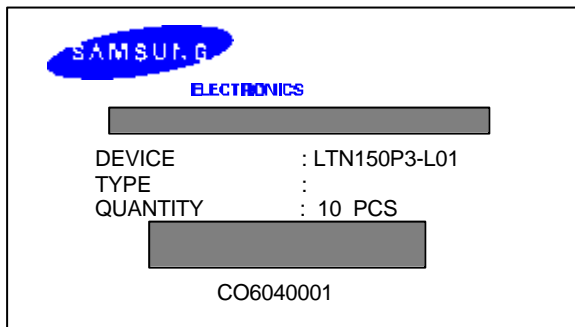

NO	PART NAME	CODE NO	SPECIFICATION	Q'TY	WEIGHT	FINISH	UPGRADED M.F. MATERIAL	REMARK
T	OUTLINE DIMENSION		LTV150P3-L01	1				

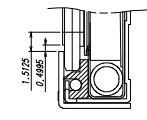

SECTION A-A' (S:5/1)

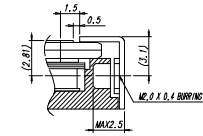

SECTION B-B' (S:5/1)

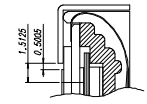

SECTION C-C' (S:5/1)

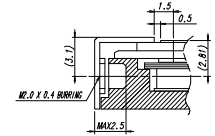

SECTION D-D' (S:5/1)

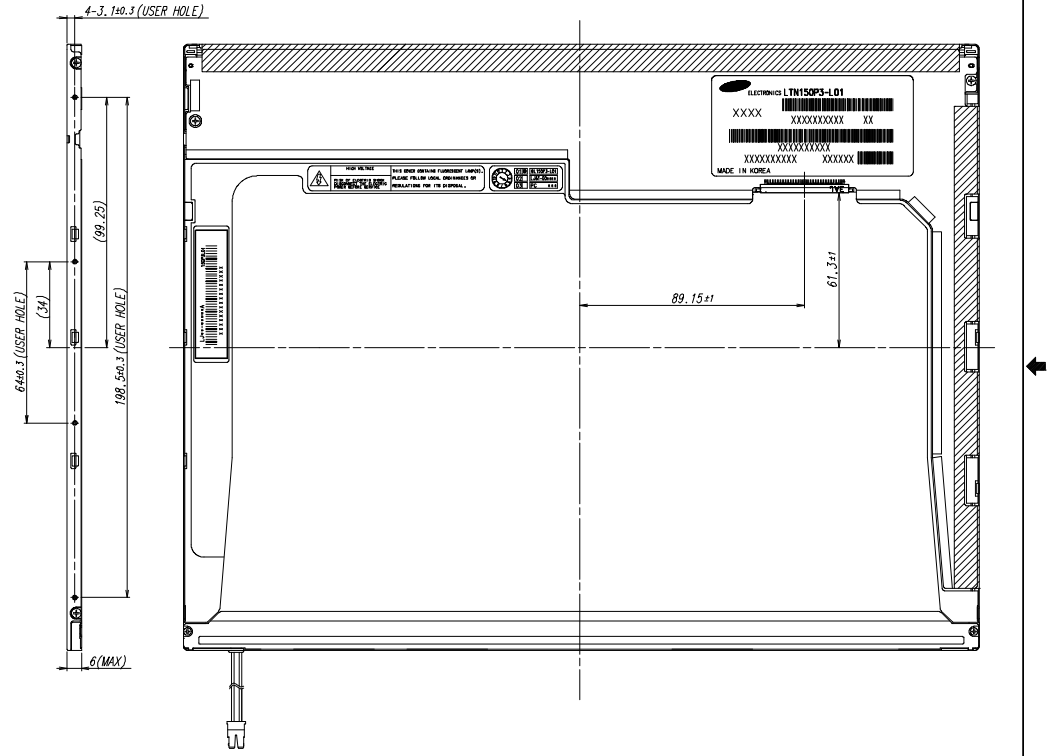
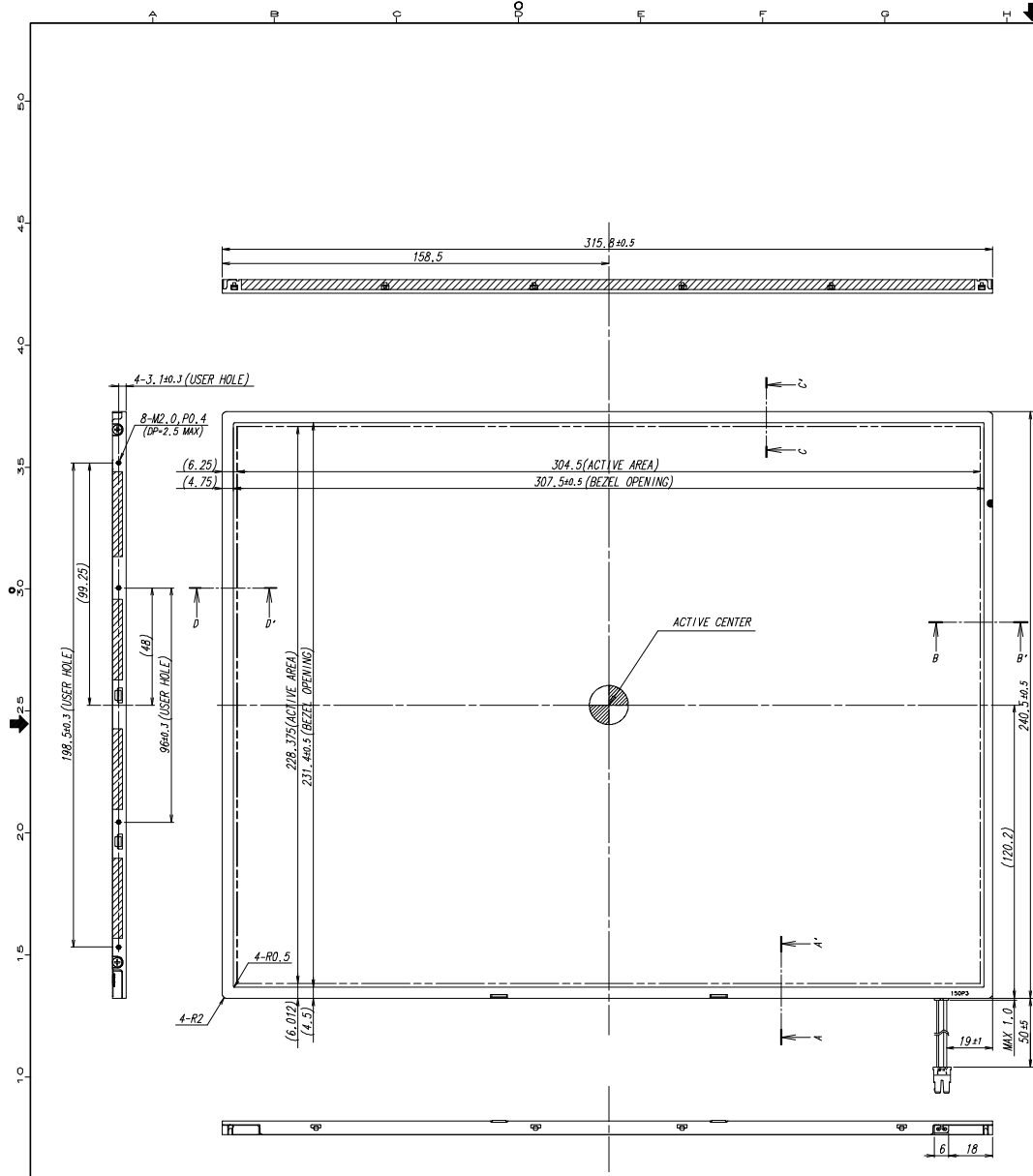

- * NOTE
- SIGNAL INTERFACE CONNECTOR TO BE SPECIFIED AS BELOW.
 - MAKER : UJU(JAE COMPATIBLE)
 - PART NO : F1-XB30S-HF10
 - CCFT CONNECTOR FOR BACKLIGHT TO BE SPECIFIED AS BELOW.
 - MAKER : JST
 - PART NO : BHSR-02VS-1

GENERAL TOLERANCE				REV. DATE	DESCRIPTION OF REVISION			REASON	CHK'D BY
STEP	LEVEL 1	LEVEL 2	LEVEL 3	UNIT	DRAW'N BY	DES'G'D BY	CHK'D BY	APP'D BY	MODEL NAME
0 < X ≤ 4	±0.05	±0.1	±0.2	SCALE	J.K.KIM	D.C.KIM	Y.B.OH		LTV150P3-L01
4 < X ≤ 16	±0.08	±0.15	±0.3	TOLERANCE					OUTLINE DIMENSION
16 < X ≤ 64	±0.12	±0.25	±0.5	LEVEL 3					PART/SHEET NAME
64 < X ≤ 256	±0.25	±0.4	±0.8						SPEC. NO
SAMSUNG ELECTRONICS								CODE NO.	VER. 00