

SAMSUNG

ELECTRONICS

Product Information



Product Information

SAMSUNG TFT-LCD

MODEL NO. : LTN121W1-L03

LCD Product Planning Group 1, Marketing Team

Samsung Electronics Co . , LTD.



SAMSUNG TFT-LCD

Doc.No.	LTN121W1-L03	ISSUED DATE	24/Nov/2006	Page	1 / 13
----------------	--------------	--------------------	-------------	-------------	--------

CONTENTS

General Description	----- (3)
1. Electrical Absolute Ratings	----- (4)
2. Optical Characteristics	----- (5)
3. Electrical Characteristics	----- (6)
3.1 TFT LCD Module	
3.2 Backlight Unit	
4. Block Diagram	----- (7)
4.1 TFT LCD Module	
4.2 Backlight Unit	
5. Input Terminal Pin Assignment	----- (8)
5.1 Input Signal & Power	
5.2 Backlight Unit	
5.3 Timing Diagrams of LVDS For Transmitting	
6. Interface Timing	----- (10)
6.1 Timing Parameters	
6.2 Timing Diagrams of interface Signal	
6.3 Power ON/OFF Sequence	
7. Outline Dimension	----- (12)

GENERAL DESCRIPTION

DESCRIPTION

LTN121W1-L03 is a color active matrix TFT (Thin Film Transistor) liquid crystal display (LCD) that uses amorphous silicon TFT as switching devices. This model is composed of a TFT LCD panel, a driver circuit and a backlight unit. The resolution of a 12.1" contains 1280 x 800 pixels and can display up to 262,144 colors. 6 O'clock direction is the Optimum viewing angle.

FEATURES

- High contrast ratio, high aperture structure
- WXGA (1280 x 800 pixels) resolution
- Low power consumption
- Fast Response
- Single CCFL
- DE(Data enable) only mode
- 3.3V LVDS Interface
- Onboard EEDID chip
- Pb-free product

APPLICATIONS

- Notebook PC
- If the usage of this product is not for PC application, but for others, please contact SEC

GENERAL INFORMATION

Item	Specification	Unit	Note
Display area	261.12(H) x 163.2(V) (12.1" wide diagonal)	mm	
Driver element	a-Si TFT active matrix		
Display colors	262,144		
Number of pixel	1280 x 800	pixel	
Pixel arrangement	RGB vertical stripe		
Pixel pitch	0.204(H) x 0.204(V) (TYP.)	mm	
Display Mode	Normally white		
Surface treatment	Haze 25(anti-glare), Hard-Coating 3H		

MECHANICAL INFORMATION

Item		Min.	Typ.	Max.	Unit	Note
Module size	Horizontal (H)	275.3	275.8	276.3	mm	
	Vertical (V)	177.5	178.0	178.5	mm	
	Depth (D)	-	5.2	5.5	mm	(1)
Weight		-	265	270	g	

Note (1) Measurement condition of outline dimension
 . Equipment : Bernier Calipers
 . Push Force : 500g · f (minimum)

1. ELECTRICAL ABSOLUTE RATINGS

(1) TFT LCD MODULE

$V_{DD} = 3.3V$, $V_{SS} = GND = 0V$

Item	Symbol	Min.	Max.	Unit	Note
Power Supply Voltage	V_{DD}	$V_{DD} - 0.3$	$V_{DD} + 0.3$	V	(1)
Logic Input Voltage	V_{IN}	$V_{DD} - 0.3$	$V_{DD} + 0.3$	V	(1)

Note (1) Within T_a ($25 \pm 2 \text{ }^\circ\text{C}$)

(2) BACK-LIGHT UNIT

$T_a = 25 \pm 2 \text{ }^\circ\text{C}$

Item	Symbol	Min.	Max.	Unit	Note
Lamp Current	I_L	3.0	7.0	mArms	(1)
Lamp frequency	F_L	50	80	kHz	(1)

Note 1) Permanent damage to the device may occur if maximum values are exceeded
 Functional operation should be restricted to the conditions described under normal operating conditions.

2. OPTICAL CHARACTERISTICS

The following items are measured under stable conditions. The optical characteristics should be measured in a dark room or equivalent state with the methods shown in Note (5).
Measuring equipment : TOPCON BM-5A and PR-650

* Ta = 25 ± 2 °C, VDD=3.3V, fv= 60Hz, fdCLK = 68.9MHz, IL = 6.0 mA

Item		Symbol	Condition	Min.	Typ.	Max	Unit
Contrast Ratio (5 Points)		CR	Normal Viewing Angle $\phi = 0$ $\theta = 0$	200	300	-	-
Response Time at Ta (Rising + Falling)		T _{RT}		-	25	35	msec
Average Luminance of White (5 Points)		Y _{L,AVE}		170	200	-	cd/m ²
Color Chromaticity (CIE)	Red	R _X	Normal Viewing Angle $\phi = 0$ $\theta = 0$	0.550	0.580	0.610	-
		R _Y		0.310	0.340	0.370	
	Green	G _X		0.290	0.320	0.350	
		G _Y		0.510	0.540	0.570	
	Blue	B _X		0.125	0.155	0.185	
		B _Y		0.095	0.125	0.155	
	White	W _X		0.283	0.313	0.343	
		W _Y		0.299	0.329	0.359	
Viewing Angle	Hor.	θ_L	CR ≥ 10 At center	40	45		Degrees
		θ_H		40	45		
	Ver.	ϕ_H		10	15		
		ϕ_L		25	30		
13 Points White Variation		δ_L		-	-	2.2	-

3. ELECTRICAL CHARACTERISTICS

3.1 TFT LCD MODULE

Ta= 25 ± 2°C

Item	Symbol	Min.	Typ.	Max.	Unit	Note	
Voltage of Power Supply	V _{DD}	3.0	3.3	3.6	V		
Differential Input Voltage for LVDS Receiver Threshold	High	V _{IH}	-	-	+100	mV	V _{CM} = +1.2V
	Low	V _{IL}	-100	-	-	mV	
Vsync Frequency	f _v	-	60	-	Hz		
Hsync Frequency	f _H	-	48.96	-	KHz		
Main Frequency	f _{DCLK}	-	68.9	-	MHz		
Rush Current	I _{RUSH}	-	-	1.5	A		
Current of Power Supply	White	I _{DD}	-	350	-	mA	
	Mosaic		-	370	-	mA	
	V. stripe		-	400	500	mA	

3.2 BACK-LIGHT UNIT

The backlight system is an edge-lighting type with a single CCFT (Cold Cathode Fluorescent Tube).
The characteristics of a single lamp are shown in the following table.

- INVERTER : SEM SIC 130T

Ta= 25 ± 2 °C

Item	Symbol	Min.	Typ.	Max.	Unit	Note
Lamp Current	I _L	3.0	6.0	6.5	mArms	
Lamp Voltage	V _L	-	620	-	Vrms	I _L = 6.0mA
Frequency	f _L	50	60	65	KHz	
Power Consumption	P _L		3.7		W	I _L = 6.0mA
Operating Life Time	Hr	10,000			Hour	
Startup Voltage	V _s			1,010	Vrms	25°C
				1,215	Vrms	0°C
Lamp Start-up time	T _s	-	-	1.0	sec	

4. BLOCK DIAGRAM

4.1 TFT LCD Module

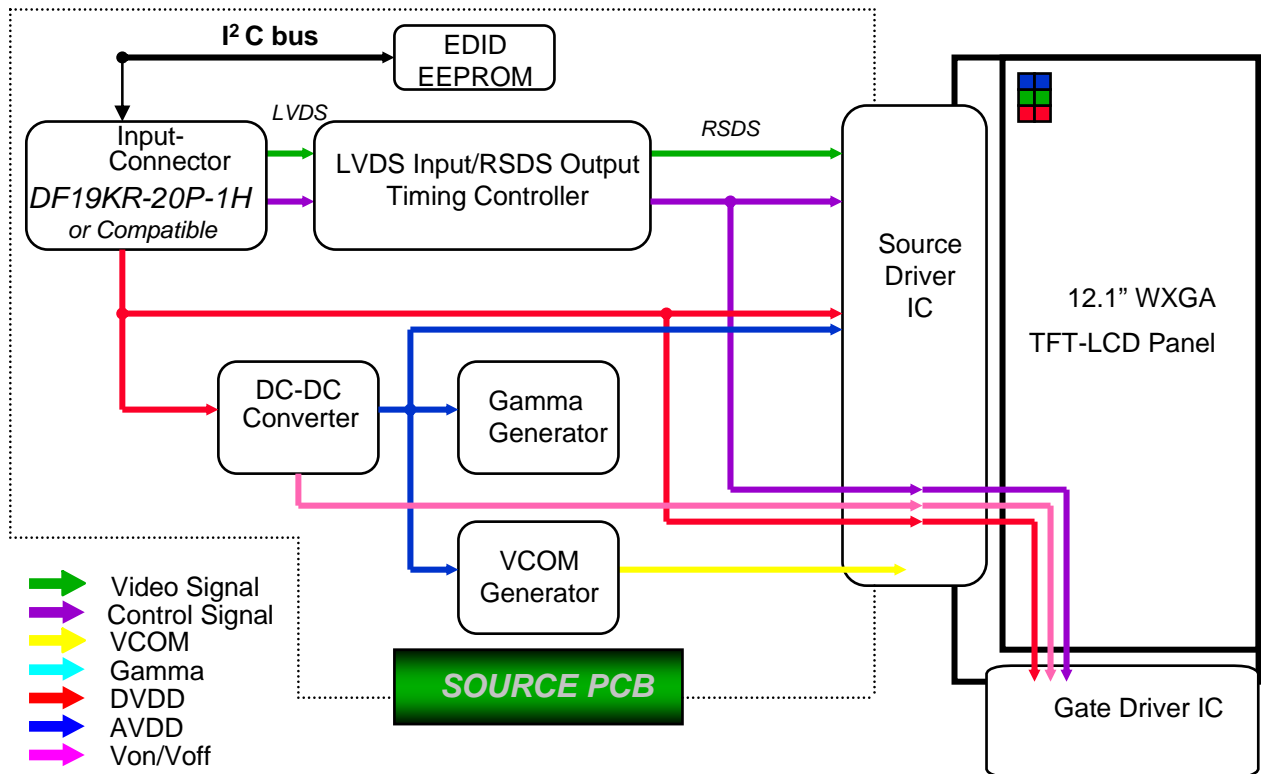

4.2 BACKLIGHT UNIT

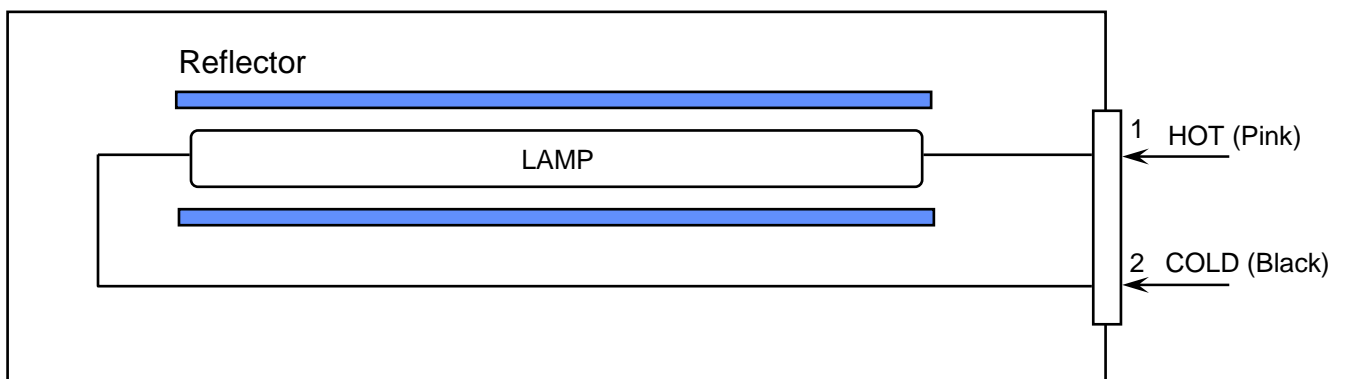

Note) The output of the inverter may change according to the material of the reflector.

5. INPUT TERMINAL PIN ASSSIGNMENT

5.1. Input Signal & Power (LVDS, Connector : DF19KR-20P-1H by Hirose or equivalent)

No.	Symbol	Function	Polarity	Remarks
1	VSS	Ground		
2	VDD	POWER SUPPLY +3.3V		
3	VDD	POWER SUPPLY +3.3V		
4	VEEDID	DDC 3.3V Power		
5	N.C	No connection	Positive	
6	CLKEDID	DDC Clock		
7	DATAEDID	DDC data		
8	RxIN0-	LVDS Differential Data INPUT (R0-R5,G0)	Negative	
9	RxIN0+	LVDS Differential Data INPUT (R0-R5,G0)	Positive	
10	GND	Ground		
11	RxIN1-	LVDS Differential Data INPUT (G1-G5,B0-B1)	Negative	
12	RxIN1+	LVDS Differential Data INPUT (Odd G1-G5,B0-B1)	Positive	
13	GND	Ground		
14	RxIN2-	LVDS Differential Data INPUT (B2-B5,Sync,DE)	Negative	
15	RxIN2+	LVDS Differential Data INPUT (B2-B5,Sync,DE)	Positive	
16	GND	Ground		
17	RxCLK-	LVDS Differential Data INPUT	Negative	
18	RxCLK+	LVDS Differential Data INPUT	Positive	
19	GND	Ground		
20	GND	Ground		

5.2 BACK LIGHT UNIT

Connector : JST BHSR - 02VS -1
 Mating Connector : SM02B-BHSS-1(JST)

Pin NO.	Symbol	Color	Function
1	HOT	Pink	High Voltage
2	COLD	Black	Low Voltage

5.3 Timing Diagrams of LVDS For Transmission

LVDS Receiver : Integrated T-CON

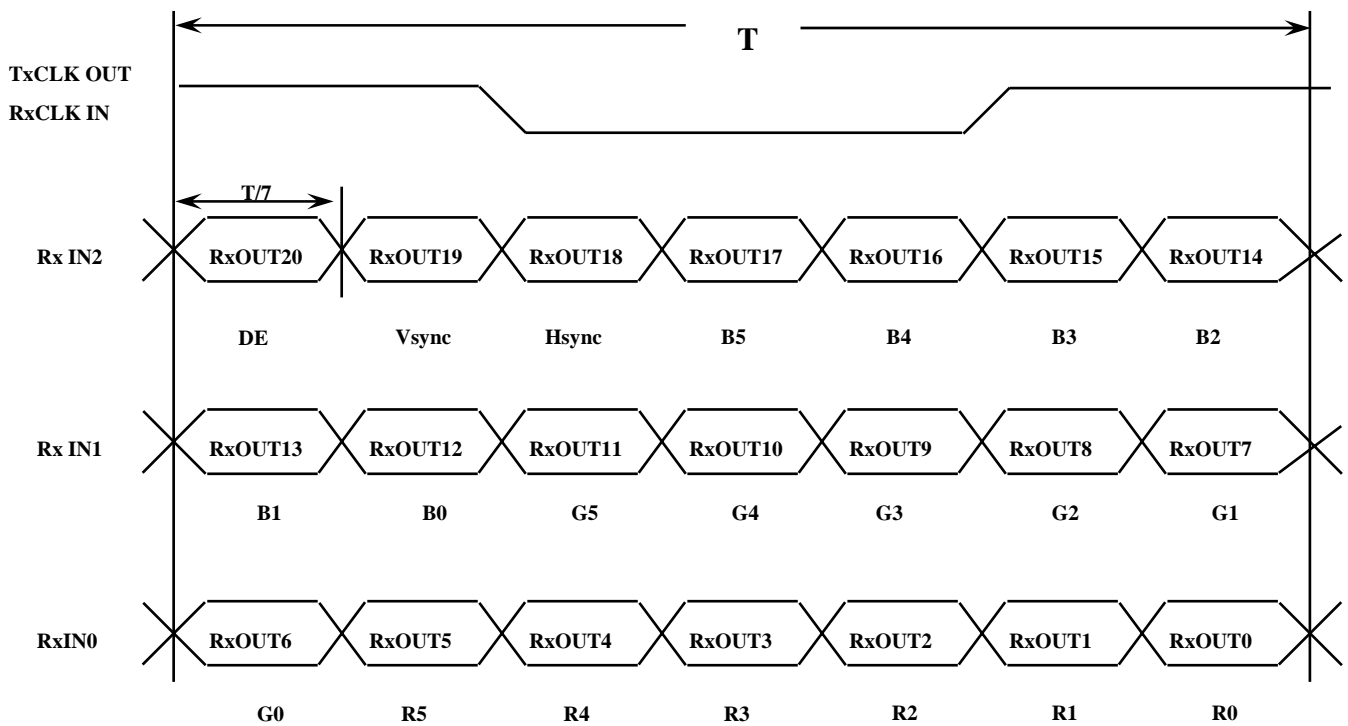

6. INTERFACE TIMING

6.1 Timing Parameters

Signal	Item	Symbol	Min.	Typ.	Max.	Unit	Note
Frame Frequency	Cycle	TV	804	816	828	Lines	
Vertical Active Display Term	Display Period	TVD	-	800	-	Lines	
One Line Scanning Time	Cycle	TH	1302	1408	1514	Clocks	
Horizontal Active Display Term	Display Period	THD	-	1280	-	Clocks	

6.2 Timing diagrams of interface signal

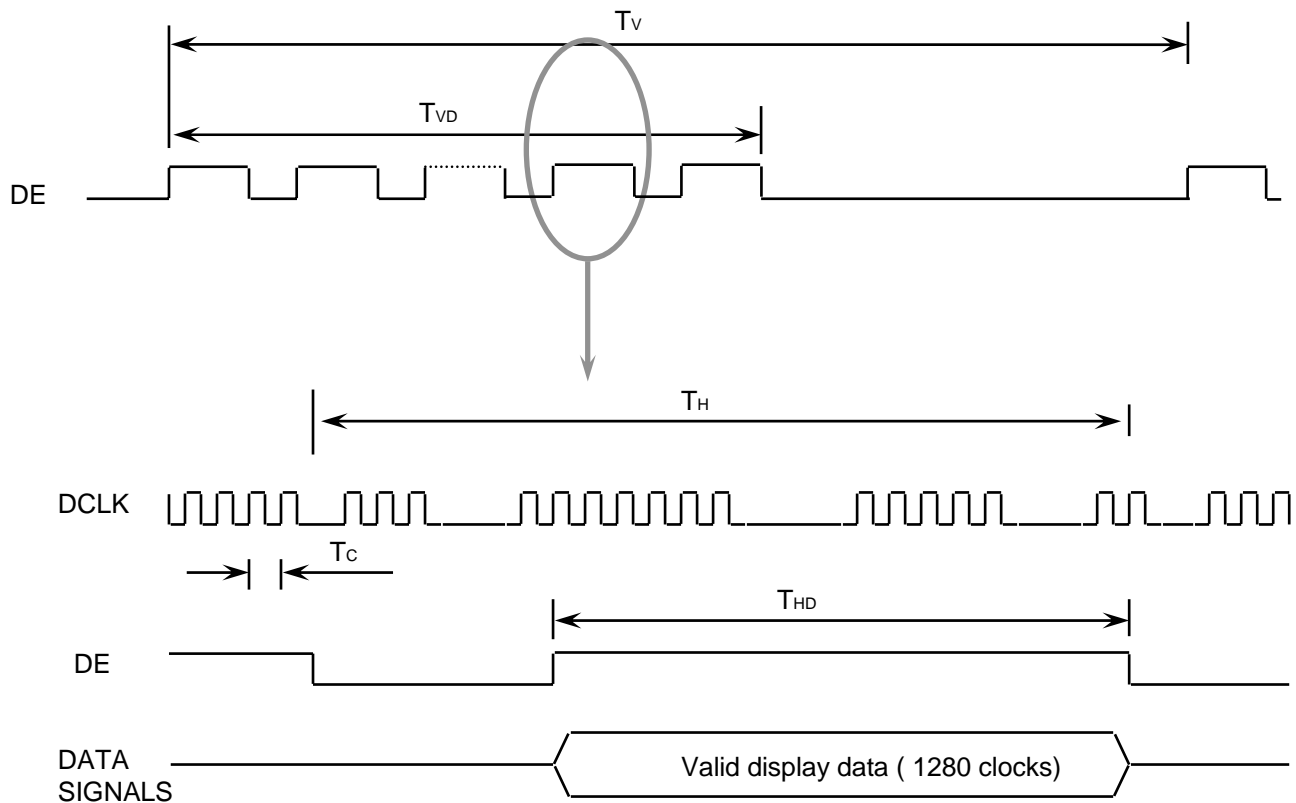

6.3 Power ON/OFF Sequence

: To prevent a latch-up or DC operation of the LCD module, the power on/off sequence should be as the diagram below.

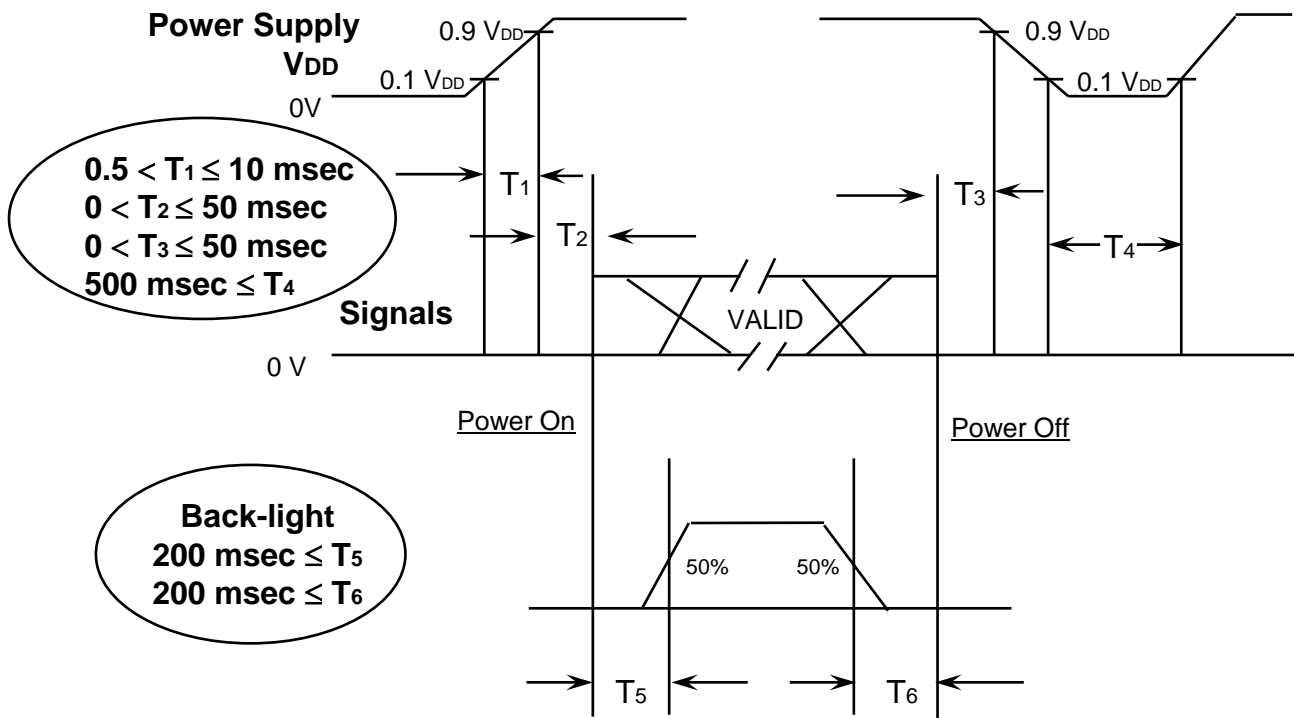

Power ON/OFF Sequence

- T1 : Vdd rising time from 10% to 90%
- T2 : The time from Vdd to valid data at power ON.
- T3 : The time from valid data off to Vdd off at power Off.
- T4 : Vdd off time for Windows restart
- T5 : The time from valid data to B/L enable at power ON.
- T6 : The time from valid data off to B/L disable at power Off.

NOTE.

- (1) The supply voltage of the external system for the module input should be the same as the definition of VDD.
- (2) Apply the lamp voltage within the LCD operation range. When the back-light turns on before the LCD operation or the LCD turns off before the back-light turns off, the display may momentarily become white.
- (3) In case of VDD = off level, please keep the level of input signals on the low or keep a high impedance.
- (4) T4 should be measured after the module has been fully discharged between power off and on period.
- (5) Interface signal shall not be kept at high impedance when the power is on.

7. MECHANICAL OUTLINE DIMENSION

[Refer to the next page]

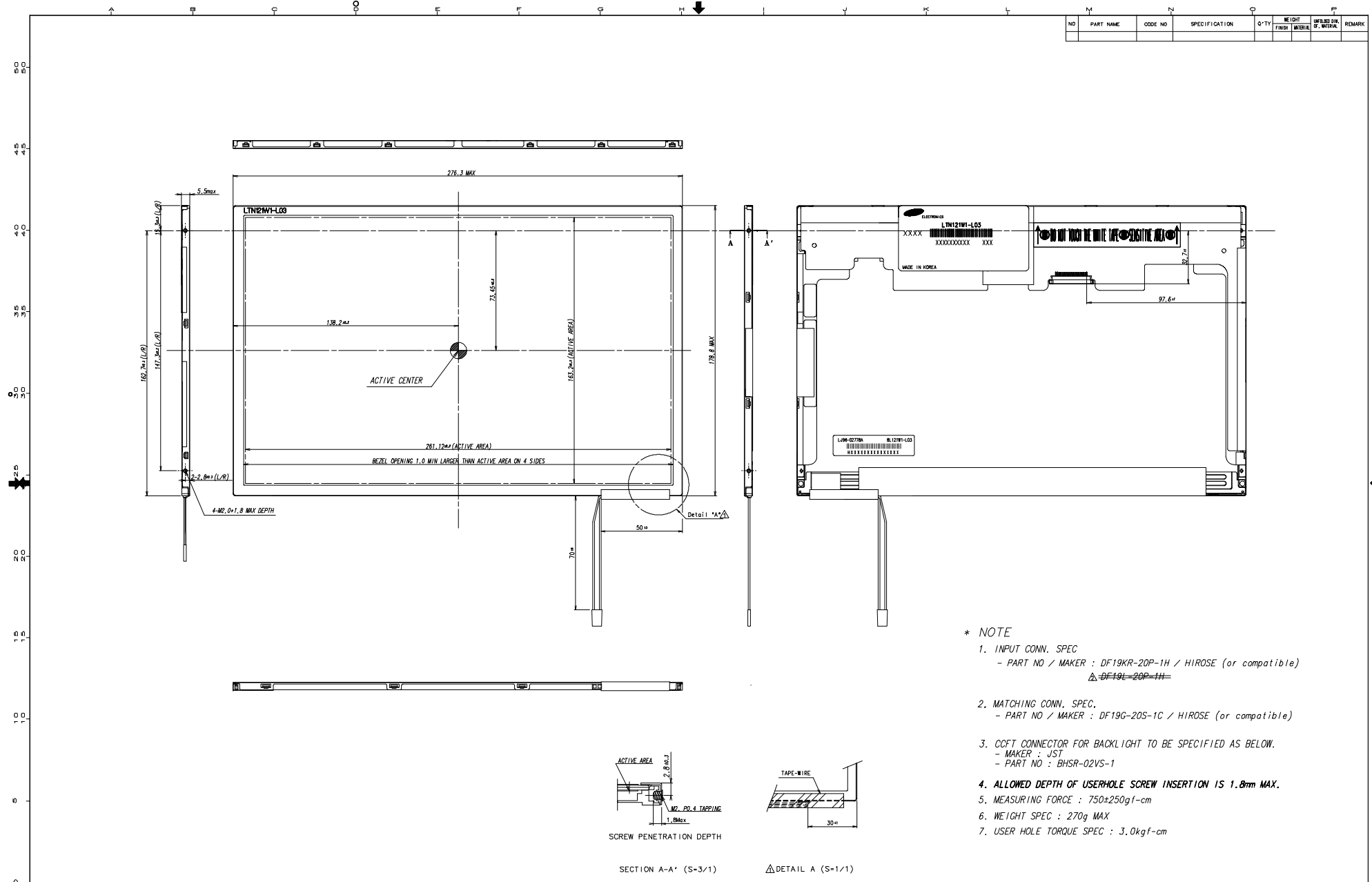

NO	PART NAME	CODE NO	SPECIFICATION	Q-TY	WEIGHT FINISH	INFLUENCE OF MATERIAL	REMARK

- * NOTE
- INPUT CONN. SPEC
- PART NO / MAKER : DF19KR-20P-1H / HIROSE (or compatible)
~~DF19L-20P-1H~~
 - MATCHING CONN. SPEC.
- PART NO / MAKER : DF19G-20S-1C / HIROSE (or compatible)
 - CCFT CONNECTOR FOR BACKLIGHT TO BE SPECIFIED AS BELOW.
- MAKER : JST
- PART NO : BHSR-02VS-1
 - ALLOWED DEPTH OF USERHOLE SCREW INSERTION IS 1.8mm MAX.
 - MEASURING FORCE : 750±250gf-cm
 - WEIGHT SPEC : 270g MAX
 - USER HOLE TORQUE SPEC : 3.0kgf-cm

REV	DATE	DESCRIPTION OF REVISION	SPEC REALIZATION	CHK'D BY
001	106.03.07	CHANGING INPUT CONNECTOR SPEC		Y.S.KIM

REV	DATE	DESCRIPTION OF REVISION	APP'D BY	MODEL NAME	PART/SHEET NAME	SHEET
001	106.03.07	ADDING PARTIAL DIMMING (DETAIL 'A')				

UNIT	SCALE	TOLERANCE	DATE	DESIGNER	DRAWN	CHECKED	APP'D BY	MODEL NAME	PART/SHEET NAME	SHEET
mm	1/1		06.03.14	Y.S.KIM	Y.S.KIM	H.S.CHUN	D.I.SHIN	LTM21W1-LOS	OUTLINE DIMENSION	1/1

REV	DATE	DESCRIPTION OF REVISION	SPEC REALIZATION	CHK'D BY