

Product Specification

SPECIFICATION FOR APPROVAL

- () Preliminary Specification
- ◆ Final Specification

Title	13.3" WXGA TFT LCD
-------	--------------------



BUYER	Dell
MODEL	

SUPPLIER	LG.Philips LCD Co., Ltd.
*MODEL	LP133WX1
Suffix	TLB1

*When you obtain standard approval, please use the above model name without suffix

APPROVED BY	SIGNATURE
/	_____
/	_____
/	_____

Please return 1 copy for your confirmation with your signature and comments.

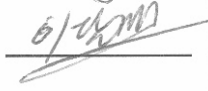
APPROVED BY	SIGNATURE
S. C. Yun / G.Manager	
REVIEWED BY	
G. J. Han / Manager	
PREPARED BY	
B. T. Jang / Engineer	
D. J. Lee / Engineer	

Products Engineering Dept.
LG. Philips LCD Co., Ltd

Product Specification

Contents

No	ITEM	Page
	COVER	1
	CONTENTS	2
	RECORD OF REVISIONS	3
1	GENERAL DESCRIPTION	4
2	ABSOLUTE MAXIMUM RATINGS	5
3	ELECTRICAL SPECIFICATIONS	
3-1	ELECTRICAL CHARACTERISTICS	6
3-2	INTERFACE CONNECTIONS	8
3-3	SIGNAL TIMING SPECIFICATIONS	9
3-4	SIGNAL TIMING WAVEFORMS	9
3-5	COLOR INPUT DATA REFERNECE	10
3-6	POWER SEQUENCE	11
4	OPTICAL SPECIFICATIONS	12
5	MECHANICAL CHARACTERISTICS	16
6	RELIABILITY	20
7	INTERNATIONAL STANDARDS	
7-1	SAFETY	21
7-2	EMC	21
8	PACKING	
8-1	DESIGNATION OF LOT MARK	22
8-2	PACKING FORM	22
9	PRECAUTIONS	23
A	APPENDIX A. Enhanced Extended Display Identification Data	25

Product Specification

1. General Description

The LP133WX1-TLB1 is a Color Active Matrix Liquid Crystal Display with an integral Cold Cathode Fluorescent Lamp (CCFL) backlight system. The matrix employs a-Si Thin Film Transistor as the active element. It is a transmissive type display operating in the normally white mode. This TFT-LCD has 13.3 inches diagonally measured active display area with WXGA resolution(800 vertical by 1280 horizontal pixel array). Each pixel is divided into Red, Green and Blue sub-pixels or dots which are arranged in vertical stripes. Gray scale or the brightness of the sub-pixel color is determined with a 6-bit gray scale signal for each dot, thus, presenting a palette of more than 262,144 colors.

The LP133WX1-TLB1 has been designed to apply the interface method that enables low power, high speed, low EMI.

The LP133WX1-TLB1 is intended to support applications where thin thickness, low power are critical factors and graphic displays are important. In combination with the vertical arrangement of the sub-pixels, the LP133WX1-TLB1 characteristics provide an excellent flat display for office automation products such as Notebook PC.

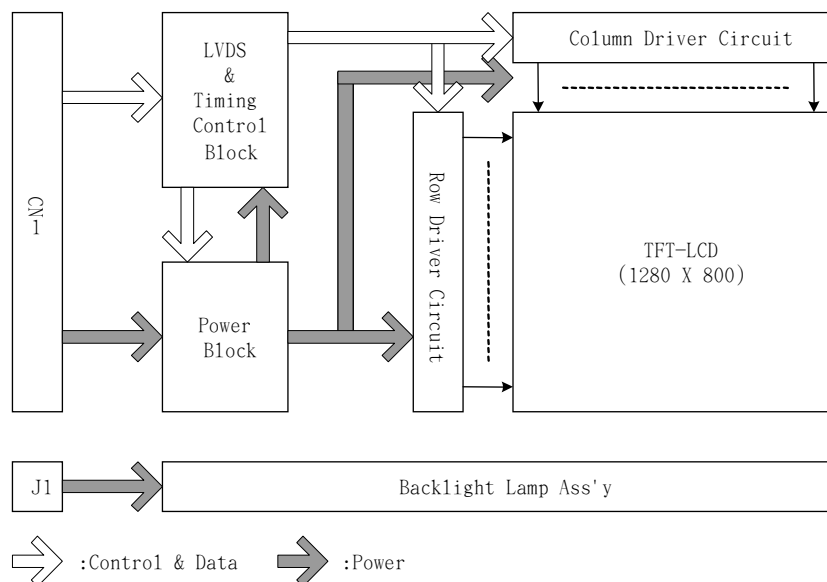

General Features

Active Screen Size	13.3 inches diagonal
Outline Dimension	299.0(H)[typ.] × 195.0(V)[typ.] × 5.5(D) mm [Max.]
Pixel Pitch	0.2235 mm × 0.2235 mm
Pixel Format	1280 horiz. By 800 vert. Pixels RGB strip arrangement
Color Depth	6-bit, 262,144 colors
Luminance, White	220 cd/m ² [typ.], 5p average
Power Consumption	Total 4.8 Watt(Typ.) @ LCM circuit 0.8 Watt(Typ.), B/L input 4.0 Watt(Typ.)
Weight	340g [Typ.] , 350g [Max.]
Display Operating Mode	Transmissive mode, normally white
Surface Treatment	Anti-Reflection & Glare, hard coating 3H

Product Specification

2. Absolute Maximum Ratings

The following are maximum values which, if exceeded, may cause faulty operation or damage to the unit.

Table 1. ABSOLUTE MAXIMUM RATINGS

Parameter	Symbol	Values		Units	Notes
		Min	Max		
Power Input Voltage	VCC	-0.3	4.0	Vdc	at 25 ± 5°C
Operating Temperature	TOP	0	50	°C	1
Storage Temperature	HST	-20	60	°C	1
Operating Ambient Humidity	HOP	10	90	%RH	1
Storage Humidity	HST	10	90	%RH	1

Note : 1. Temperature and relative humidity range are shown in the figure below.
Wet bulb temperature should be 39°C Max, and no condensation of water.

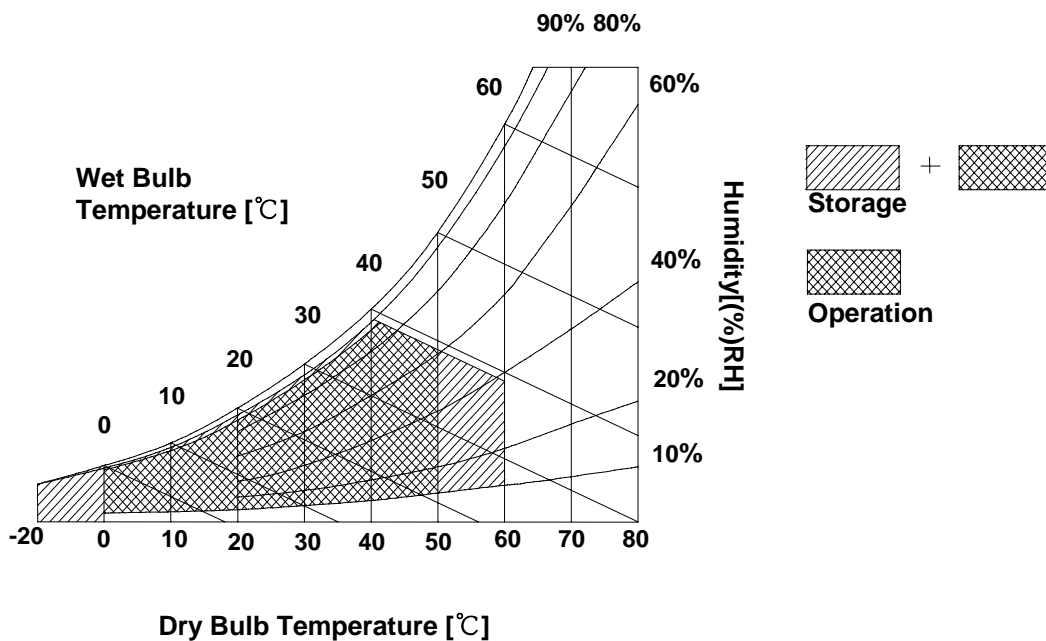

Product Specification

3. Electrical Specifications

3-1. Electrical Characteristics

The LP133WX1-TLB1 requires two power inputs. One is employed to power the LCD electronics and to drive the TFT array and liquid crystal. The second input which powers the CCFL, is typically generated by an inverter. The inverter is an external unit to the LCD.

Table 2. ELECTRICAL CHARACTERISTICS

Parameter	Symbol	Values			Unit	Notes
		Min	Typ	Max		
MODULE :						
Power Supply Input Voltage	VCC	3.0	3.3	3.6	V _{dc}	
Power Supply Input Current	I _{CC}	-	245	280	mA	Mosaic
Power Consumption	P _c	-	0.8	0.9	Watts	1
Differential Impedance	Z _m	100	110	120	Ohm	2
LAMP :						
Operating Voltage	V _{BL}	605	620	855	V _{RMS}	3
Operating Current	I _{BL}	2.0	6.5	7.0	mA _{RMS}	4
Power Consumption	P _{BL}		4.0	4.2		
Operating Frequency	f _{BL}	45	60	80	kHz	7
Discharge Stabilization Time	T _s	-	-	3	Min	5
Life Time		15000			Hrs	6
Established Starting Voltage at 25°C at 0 °C	V _s			1140 1370	V _{RMS} V _{RMS}	8

Note)

- The specified current and power consumption are under the Vcc = 3.3V , 25°C, fv = 60Hz condition whereas Mosaic pattern is displayed and fv is the frame frequency.
- This impedance value is needed to proper display and measured from LVDS Tx to the mating connector.
- The variance of the voltage is ± 10%.
- The typical operating current is for the typical surface luminance (L_{WH}) in optical characteristics.
- Define the brightness of the lamp after being lighted for 5 minutes as 100%, T_s is the time required for the brightness of the center of the lamp to be not less than 95%.
- The life time is determined as the time at which brightness of lamp is 50% compare to that of initial value at the typical lamp current.
- The output of the inverter must have symmetrical(negative and positive) voltage waveform and symmetrical current waveform.(Asymmetrical ratio is less than 10%) Please do not use the inverter which has asymmetrical voltage and asymmetrical current and spike wave.
Lamp frequency may produce interface with horizontal synchronous frequency and as a result this may cause beat on the display. Therefore lamp frequency shall be as away possible from the horizontal synchronous frequency and from its harmonics in order to prevent interference.
- The voltage above VS should be applied to the lamps for more than 1 second for start-up. Otherwise, the lamps may not be turned on. The used lamp current is the lamp typical current.
- The lamp power consumption shown above does not include loss of external inverter.
The applied lamp current is a typical one.

Product Specification

Note)

9. Requirements for a system inverter design, which is intended to have a better display performance, a better power efficiency and a more reliable lamp, are following.

It shall help increase the lamp lifetime and reduce leakage current.

- a. The asymmetry rate of the inverter waveform should be less than 10%.
 - b. The distortion rate of the waveform should be within $\sqrt{2} \pm 10\%$.
- * Inverter output waveform had better be more similar to ideal sine wave.

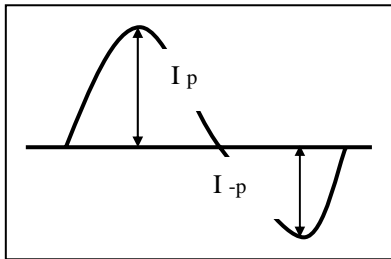

* Asymmetry rate:

$$\frac{|I_p - I_{-p}|}{I_{rms}} * 100\%$$

* Distortion rate

$$I_p \text{ (or } I_{-p}) / I_{rms}$$

- ❖ Do not attach a conducting tape to lamp connecting wire.
 If the lamp wire attach to a conducting tape, TFT-LCD Module has a low luminance and the inverter has abnormal action. Because leakage current is occurred between lamp wire and conducting tape.

Product Specification

3-2. Interface Connections

This LCD employs two interface connections, a 30 pin connector is used for the module electronics interface and the other connector is used for the integral backlight system.

The electronics interface connector is a model FI-XB30SR-HF11 manufactured by JAE.

Table 3. MODULE CONNECTOR PIN CONFIGURATION (CN1)

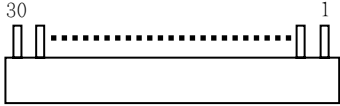
Pin	Symbol	Description	Notes
1	GND	Ground	<p>1, Interface chips 1.1 LCD : THINE , LVDSRX_SPI_UMOD (LCD Controller) including LVDS Receiver 1.2 System : it must include international standard LVDS Transmitter. * Pin to Pin compatible with LVDS</p> <p>2. Connector 2.1 LCD : FI-XB30SRL-HF11, JAE or its compatibles 2.2 Mating : FI-X30M or equivalent. 2.3 Connector pin arrangement</p>  <p>[LCD Module Rear View]</p>
2	VCC	Power Supply, 3.3V Typ.	
3	VCC	Power Supply, 3.3V Typ.	
4	V EEDID	DDC 3.3V power	
5	BIST	Built-In Self Test	
6	Clk EEDID	DDC Clock	
7	DATA EEDID	DDC Data	
8	R _{IN} 0-	Negative LVDS differential data input	
9	R _{IN} 0+	Positive LVDS differential data input	
10	GND	Ground	
11	R _{IN} 1-	Negative LVDS differential data input	
12	R _{IN} 1+	Positive LVDS differential data input	
13	GND	Ground	
14	R _{IN} 2-	Negative LVDS differential data input	
15	R _{IN} 2+	Positive LVDS differential data input	
16	GND	Ground	
17	CLKIN-	Negative LVDS differential clock input	
18	CLKIN+	Positive LVDS differential clock input	
19	GND	Ground	
20	NC	No Connect	
21	NC	No Connect	
22	NC	No Connect	
23	NC	No Connect	
24	NC	No Connect	
25	NC	No Connect	
26	NC	No Connect	
27	NC	No Connect	
28	NC	No Connect	
29	NC	No Connect	
30	NC	No Connect	

The backlight interface connector is a model BHSR-02VS-1, manufactured by JST or Compatible.
The mating connector part number is SM02B-BHSS-1 or equivalent.

Pin	Symbol	Description	Notes
1	HV	Power supply for lamp (High voltage side)	1
2	LV	Power supply for lamp (Low voltage side)	1

Notes : 1. The high voltage side terminal is colored skyblue and the low voltage side terminal is white.

Product Specification

3-3. Signal Timing Specifications

This is the signal timing required at the input of the User connector. All of the interface signal timing should be satisfied with the following specifications and specifications of LVDS Tx/Rx for it's proper operation.

Table 6. TIMING TABLE

ITEM	Symbol	Min	Typ	Max	Unit	Note
DCLK	Frequency	fCLK	67.5	71.5	74.5	MHz
Hsync	Period	Thp	1366	1440	1488	tCLK
	Width	tWH	16	32	48	
	Active	tWHA	1280	1280	1280	
Vsync	Period	tVP	811	827	847	tHP
	Width	tWV	3	6	9	
	Active	tWVA	800	800	800	
Data Enable	Horizontal back porch	tHBP	54	80	98	tCLK
	Horizontal front porch	tHFP	16	48	62	
	Vertical back porch	tVBP	5	18	35	tHP
	Vertical front porch	tVFP	3	3	3	

3-4. Signal Timing Waveforms

Condition : VCC = 3.3V

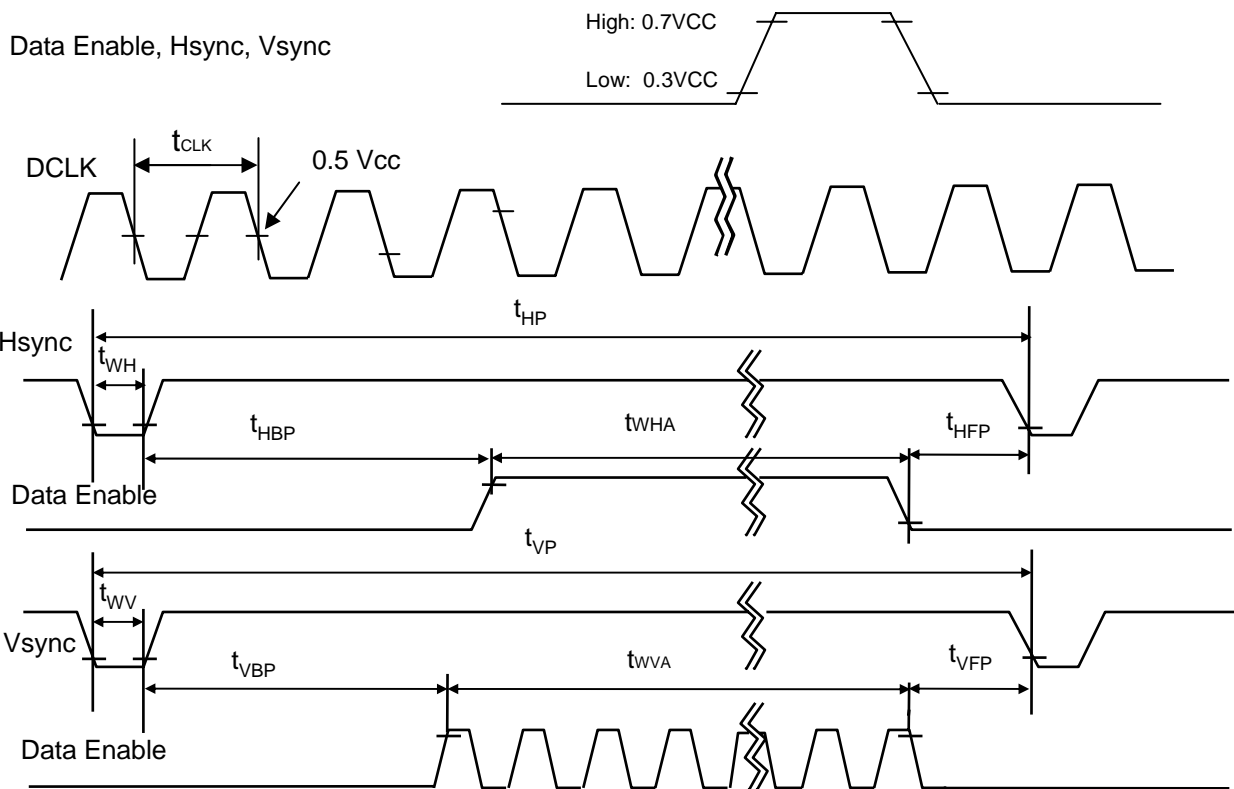

Product Specification

3-5. Color Input Data Reference

The brightness of each primary color (red, green and blue) is based on the 6-bit gray scale data input for the color ; the higher the binary input, the brighter the color. The table below provides a reference for color versus data input.

Table 7. COLOR DATA REFERENCE

Color		Input Color Data																					
		RED						GREEN						BLUE									
		MSB						LSB		MSB						LSB		MSB					
		R5	R4	R3	R2	R1	R0	G5	G4	G3	G2	G1	G0	B5	B4	B3	B2	B1	B0				
Basic Color	Black	0	0	0	0	0	0	0	0	0	0	0	0	0	0	0	0	0	0				
	Red	1	1	1	1	1	1	0	0	0	0	0	0	0	0	0	0	0	0				
	Green	0	0	0	0	0	0	1	1	1	1	1	1	0	0	0	0	0	0				
	Blue	0	0	0	0	0	0	0	0	0	0	0	0	1	1	1	1	1	1				
	Cyan	0	0	0	0	0	0	1	1	1	1	1	1	1	1	1	1	1	1				
	Magenta	1	1	1	1	1	1	0	0	0	0	0	0	1	1	1	1	1	1				
	Yellow	1	1	1	1	1	1	1	1	1	1	1	1	0	0	0	0	0	0				
	White	1	1	1	1	1	1	1	1	1	1	1	1	1	1	1	1	1	1				
RED	RED (00)	0	0	0	0	0	0	0	0	0	0	0	0	0	0	0	0	0	0				
	RED (01)	0	0	0	0	0	1	0	0	0	0	0	0	0	0	0	0	0	0				
									
	RED (62)	1	1	1	1	1	0	0	0	0	0	0	0	0	0	0	0	0	0				
	RED (63)	1	1	1	1	1	1	0	0	0	0	0	0	0	0	0	0	0	0				
GREEN	GREEN (00)	0	0	0	0	0	0	0	0	0	0	0	0	0	0	0	0	0	0				
	GREEN (01)	0	0	0	0	0	0	0	0	0	0	0	1	0	0	0	0	0	0				
									
	GREEN (62)	0	0	0	0	0	0	1	1	1	1	1	0	0	0	0	0	0	0				
	GREEN (63)	0	0	0	0	0	0	1	1	1	1	1	1	0	0	0	0	0	0				
BLUE	BLUE (00)	0	0	0	0	0	0	0	0	0	0	0	0	0	0	0	0	0	0				
	BLUE (01)	0	0	0	0	0	0	0	0	0	0	0	0	0	0	0	0	0	1				
									
	BLUE (62)	0	0	0	0	0	0	0	0	0	0	0	0	1	1	1	1	1	0				
	BLUE (63)	0	0	0	0	0	0	0	0	0	0	0	0	1	1	1	1	1	1				

Product Specification

3-6. Power Sequence

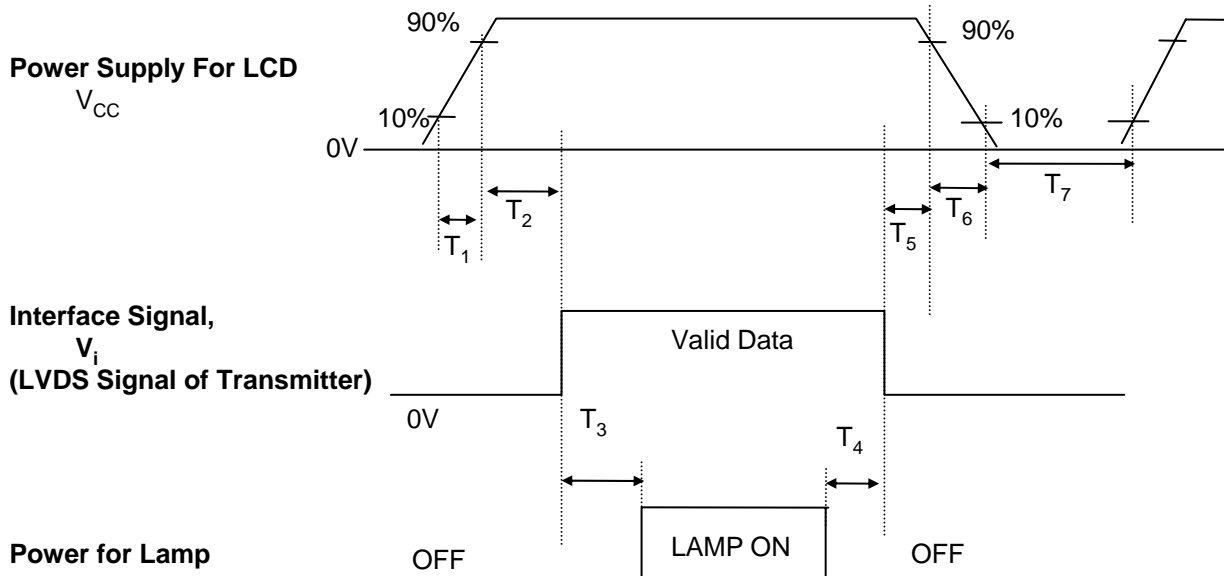

Table 8. POWER SEQUENCE TABLE

Parameter	Value			Units
	Min.	Typ.	Max.	
T ₁	0.5	-	10	(ms)
T ₂	0	-	50	(ms)
T ₃	200	-	-	(ms)
T ₄	200	-	-	(ms)
T ₅	0	-	50	(ms)
T ₆	0	-	10	(ms)
T ₇	200	-	-	(ms)

Note)

1. Please avoid floating state of interface signal at invalid period.
2. When the interface signal is invalid, be sure to pull down the power supply for LCD VCC to 0V.
3. Lamp power must be turn on after power supply for LCD and interface signal are valid.

Product Specification

4. Optical Specification

Optical characteristics are determined after the unit has been 'ON' and stable for approximately 30 minutes in a dark environment at 25°C. The values specified are at an approximate distance 50cm from the LCD surface at a viewing angle of Φ and Θ equal to 0°.

FIG. 1 Presents additional information concerning the measurement equipment and method.

FIG. 1 Optical Characteristic Measurement Equipment and Method

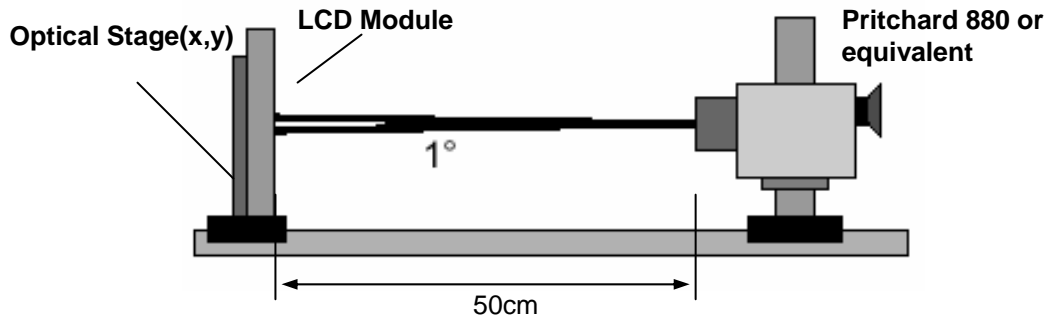

Table 9. OPTICAL CHARACTERISTICS

Ta=25°C, VCC=3.3V, fv=60Hz, fCLK= 71.5MHz, Iout = 6.5mA

Parameter	Symbol	Values			Units	Notes
		Min	Typ	MAx		
Contrast Ratio	CR	500	-	-		1
Surface Luminance, white	L _{WH}	200	220	-	cd/m ²	2
Luminance Variation	δ_{WHITE}		-	1.7		3
Response Time						4
Rise Time+Decay Time	T _R +T _D	-	25	35	ms	
Color Coordinates						
RED	RX	0.570	0.595	0.620		
	RY	0.320	0.345	0.370		
GREEN	GX	0.308	0.333	0.358		
	GY	0.516	0.541	0.566		
BLUE	BX	0.135	0.160	0.185		
	BY	0.129	0.154	0.179		
WHITE	WX	0.288	0.313	0.338		
	WY	0.304	0.329	0.354		
Viewing Angle						5
x axis, right($\Phi=0^\circ$)	Θ_r	40	45	-	degree	
x axis, left ($\Phi=180^\circ$)	Θ_l	40	45	-	degree	
y axis, up ($\Phi=90^\circ$)	Θ_u	10	15	-	degree	
y axis, down ($\Phi=270^\circ$)	Θ_d	30	35	-	degree	
Gray Scale			-			6

Product Specification

Note)

1. Contrast Ratio(CR) is defined mathematically as

$$\text{Contrast Ratio} = \frac{\text{Surface Luminance with all white pixels}}{\text{Surface Luminance with all black pixels}}$$

2. Surface luminance is the average of 5 point across the LCD surface 50cm from the surface with all pixels displaying white. For more information see FIG 1.

$$L_{WH} = \text{Average}(L_1, L_2, \dots L_5)$$

3. The variation in surface luminance , The panel total variation (δ_{WHITE}) is determined by measuring L_N at each test position 1 through 13 and then defined as followed numerical formula.
 For more information see FIG 2.

$$\delta_{WHITE} = \frac{\text{Maximum}(L_1, L_2, \dots L_{13})}{\text{Minimum}(L_1, L_2, \dots L_{13})}$$

4. Response time is the time required for the display to transition from white to black (rise time, Tr_R) and from black to white(Decay Time, Tr_D). For additional information see FIG 3.

5. Viewing angle is the angle at which the contrast ratio is greater than 10. The angles are determined for the horizontal or x axis and the vertical or y axis with respect to the z axis which is normal to the LCD surface. For more information see FIG 4.

6. Gray scale specification

* $f_V = 60\text{Hz}$

Gray Level	Luminance [%] (Typ)
L0	0.16
L7	1.45
L15	5.36
L23	12.21
L31	21.01
L39	34.82
L47	52.49
L55	74.17
L63	100

Product Specification

FIG. 2 Luminance

<measuring point for surface luminance & measuring point for luminance variation>

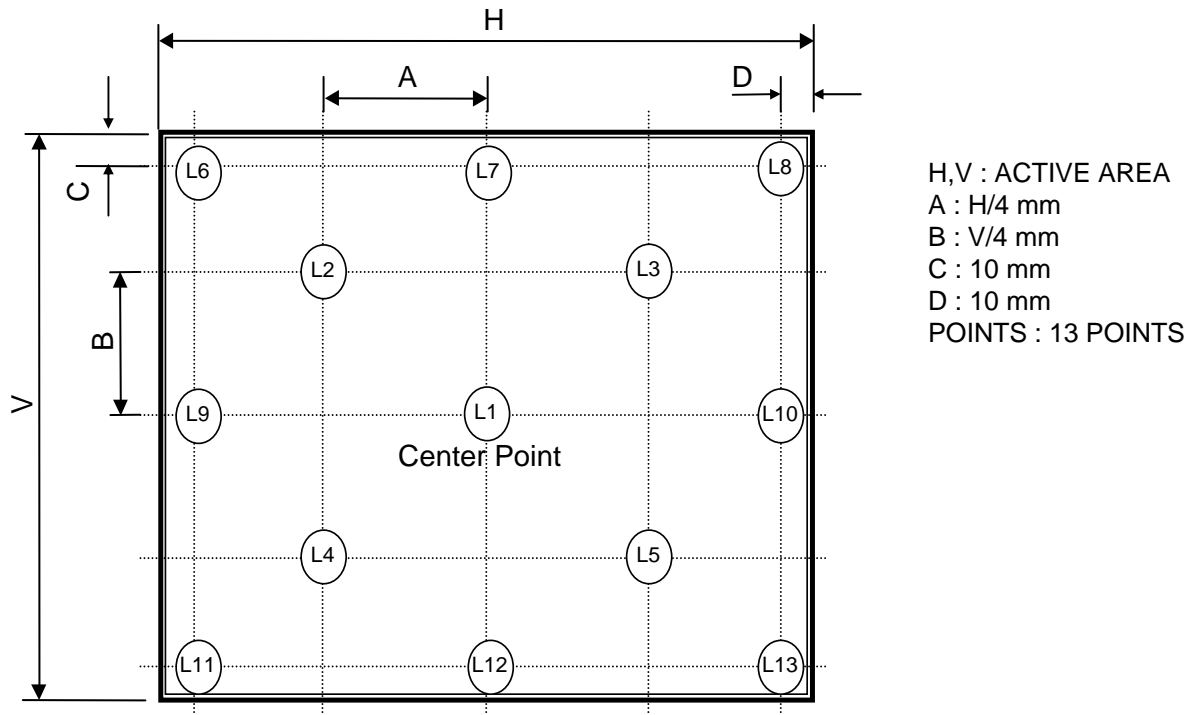
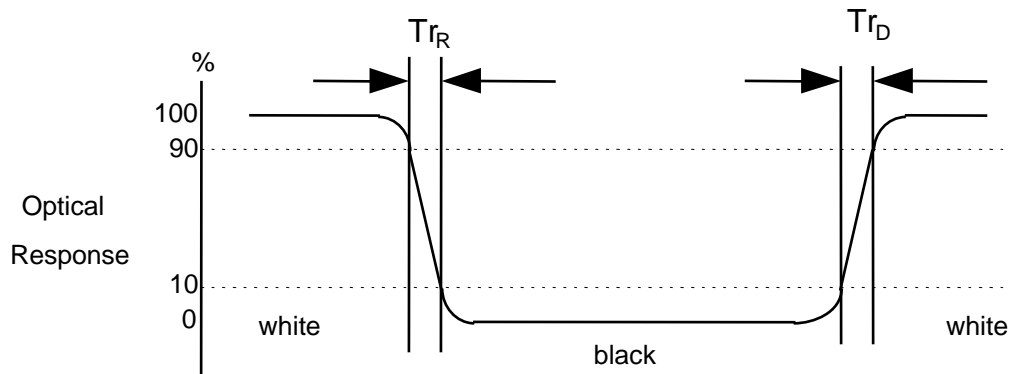

FIG. 3 Response Time

The response time is defined as the following figure and shall be measured by switching the input signal for "black" and "white".



Product Specification

FIG. 4 Viewing angle

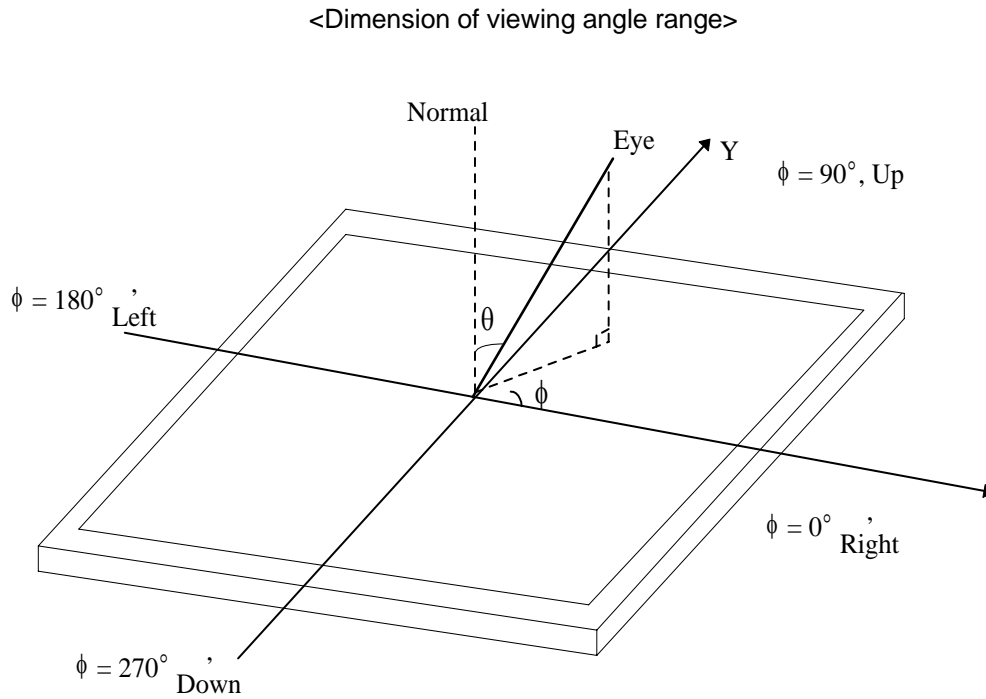

Product Specification

5. Mechanical Characteristics

The contents provide general mechanical characteristics for the model LP133WX1-TLB1.
In addition the figures in the next page are detailed mechanical drawing of the LCD.

Outline Dimension	Horizontal	299.0 ± 0.5 mm
	Vertical	195.0 ± 0.5 mm
	Depth	5.5mm MAX
Bezel Area	Horizontal	289.5 ± 0.5 mm
	Vertical	182.2 ± 0.5 mm
Active Display Area	Horizontal	286.08 mm
	Vertical	178.8 mm
Weight	340g Typ, 350g Max (W/O Inverter)	
Surface Treatment	Anti-Reflection & Glare, hard coating 3H	

Product Specification

<FRONT VIEW>

Note) Unit:[mm], General tolerance: $\pm 0.5\text{mm}$

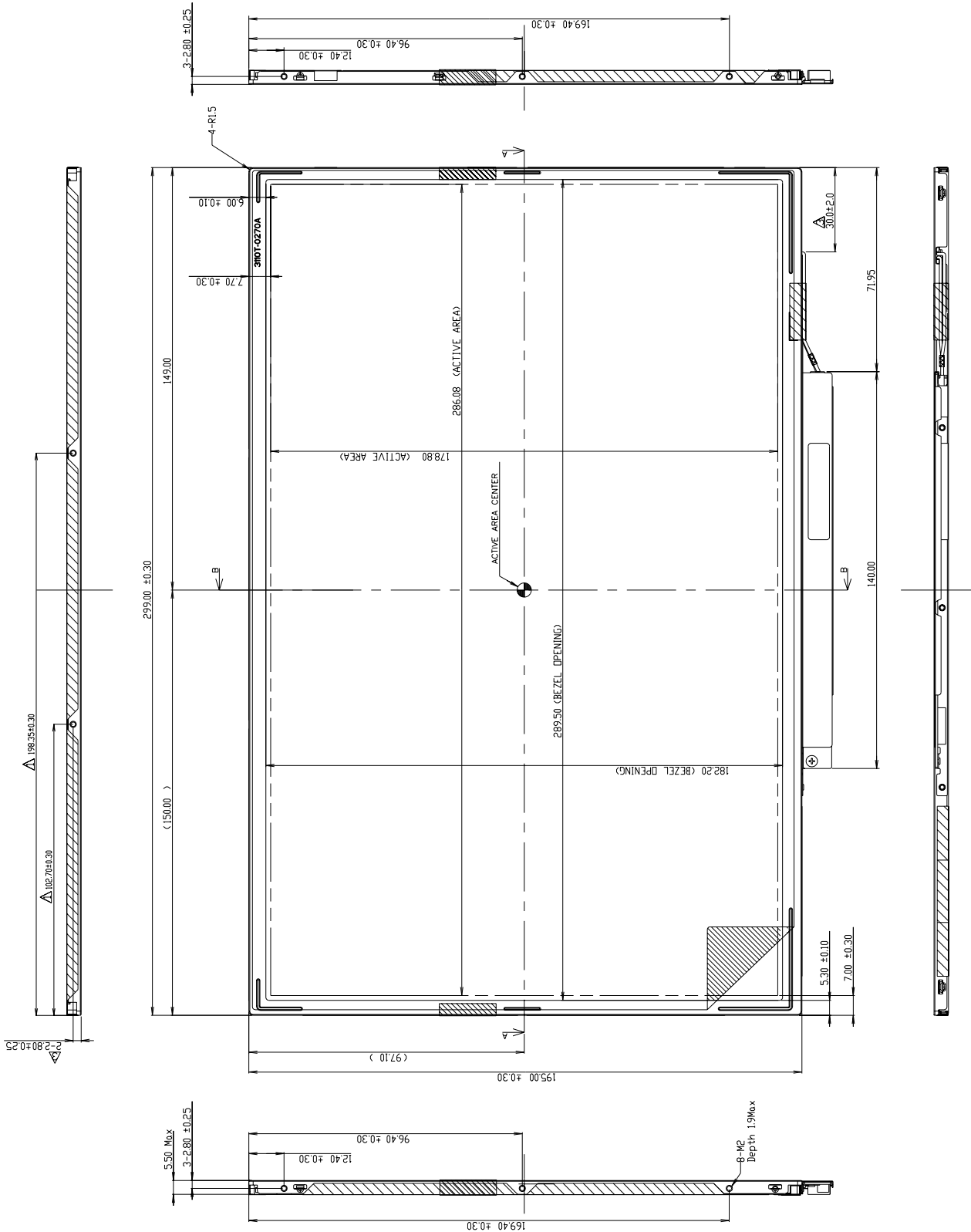

Product Specification

<REAR VIEW>

Note) Unit:[mm], General tolerance: ± 0.5mm

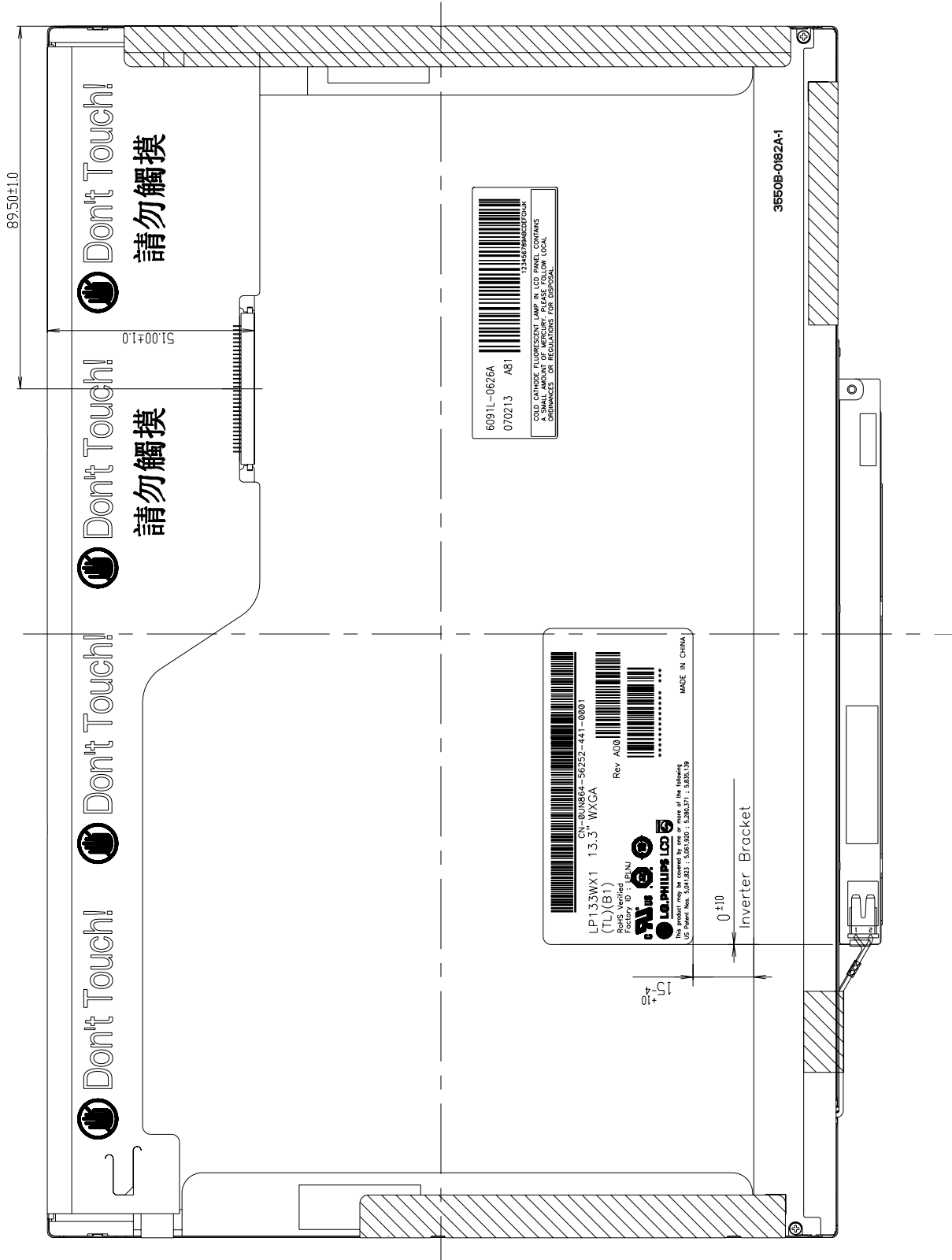

Product Specification

[DETAIL DESCRIPTION OF SIDE MOUNTING SCREW]

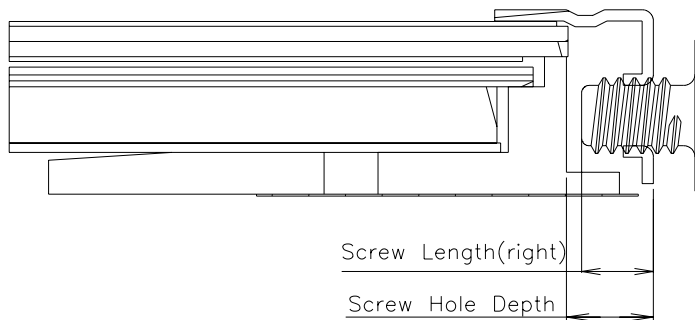

SECTION A-A

- * Screw Length : Left and Right (Max : 2.3, Min : 1.9)
- * Screw Hole Depth : Max 2.5, Min 2.3
- * Screw Torque : Max 2.0kgf.cm

Notes : 1. Screw plated through the method of non-electrolytic nickel plating is preferred to reduce possibility that results in vertical and/or horizontal line defect due to the conductive particles from screw surface.

Product Specification

6. Reliability

Environment test condition

No.	Test Item	Conditions
1	High temperature storage test	Ta= 60°C, 240h
2	Low temperature storage test	Ta= -20°C, 240h
3	High temperature operation test	Ta= 50°C, 50%RH, 240h
4	Low temperature operation test	Ta= 0°C, 240h
5	Vibration test (non-operating)	Sine wave, 10 ~ 500 ~ 10Hz, 1.5G, 0.37oct/min 3 axis, 1hour/axis
6	Shock test (non-operating)	Half sine wave, 180G, 2ms one shock of each six faces(l.e. run 180G 2ms for all six faces)
7	Altitude operating storage / shipment	0 ~ 10,000 feet (3,048m) 24Hr 0 ~ 40,000 feet (12,192m) 24Hr

{ Result Evaluation Criteria }

There should be no change which might affect the practical display function when the display quality test is conducted under normal operating condition.

7. International Standards

7-1. Safety

- a) UL 60950-1:2003, First Edition, Underwriters Laboratories, Inc., Standard for Safety of Information Technology Equipment.
- b) CAN/CSA C22.2, No. 60950-1-03 1st Ed. April 1, 2003, Canadian Standards Association, Standard for Safety of Information Technology Equipment.
- c) EN 60950-1:2001, First Edition, European Committee for Electrotechnical Standardization(CENELEC) European Standard for Safety of Information Technology Equipment.

7-2. EMC

- a) ANSI C63.4 "Methods of Measurement of Radio-Noise Emissions from Low-Voltage Electrical and Electrical Equipment in the Range of 9kHz to 40GHz. "American National Standards Institute(ANSI), 1992
- b) C.I.S.P.R. "Limits and Methods of Measurement of Radio Interface Characteristics of Information Technology Equipment." International Special Committee on Radio Interference.
- c) EN 55022 "Limits and Methods of Measurement of Radio Interface Characteristics of Information Technology Equipment." European Committee for Electrotechnical Standardization.(CENELEC), 1998 (Including A1: 2000)

Product Specification

8. Packing

8-1. Designation of Lot Mark

a) Lot Mark

A	B	C	D	E	F	G	H	I	J	K	L	M
---	---	---	---	---	---	---	---	---	---	---	---	---

A,B,C : SIZE(INCH)
E : MONTH

D : YEAR
F ~ M : SERIAL NO.

Note

1. YEAR

Year	2001	2002	2003	2004	2005	2006	2007	2008	2009	2010
Mark	1	2	3	4	5	6	7	8	9	0

2. MONTH

Month	Jan	Feb	Mar	Apr	May	Jun	Jul	Aug	Sep	Oct	Nov	Dec
Mark	1	2	3	4	5	6	7	8	9	A	B	C

b) Location of Lot Mark

Serial No. is printed on the label. The label is attached to the backside of the LCD module.
This is subject to change without prior notice.

8-2. Packing Form

a) Package quantity in one box : 30 pcs

b) Box Size : 480mmX386mmX284mm

Product Specification

9. PRECAUTIONS

Please pay attention to the following when you use this TFT LCD module.

9-1. MOUNTING PRECAUTIONS

- (1) You must mount a module using holes arranged in four corners or four sides.
- (2) You should consider the mounting structure so that uneven force(ex. Twisted stress) is not applied to the module.
And the case on which a module is mounted should have sufficient strength so that external force is not transmitted directly to the module.
- (3) Please attach a transparent protective plate to the surface in order to protect the polarizer.
Transparent protective plate should have sufficient strength in order to resist external force.
- (4) You should adopt radiation structure to satisfy the temperature specification.
- (5) Acetic acid type and chlorine type materials for the cover case are not describe because the former generates corrosive gas of attacking the polarizer at high temperature and the latter causes circuit break by electro-chemical reaction.
- (6) Do not touch, push or rub the exposed polarizers with glass, tweezers or anything harder than HB pencil lead. And please do not rub with dust clothes with chemical treatment.
Do not touch the surface of polarizer for bare hand or greasy cloth.(Some cosmetics are determined to the polarizer.)
- (7) When the surface becomes dusty, please wipe gently with absorbent cotton or other soft materials like chamois soaks with petroleum benzene. Normal-hexane is recommended for cleaning the adhesives used to attach front / rear polarizers. Do not use acetone, toluene and alcohol because they cause chemical damage to the polarizer.
- (8) Wipe off saliva or water drops as soon as possible. Their long time contact with polarizer causes deformations and color fading.
- (9) Do not open the case because inside circuits do not have sufficient strength.

9-2. OPERATING PRECAUTIONS

- (1) The spike noise causes the mis-operation of circuits. It should be lower than following voltage :
 $V = \pm 200\text{mV}$ (Over and under shoot voltage)
- (2) Response time depends on the temperature.(In lower temperature, it becomes longer.)
- (3) Brightness depends on the temperature. (In lower temperature, it becomes lower.)
And in lower temperature, response time(required time that brightness is stable after turned on) becomes longer.
- (4) Be careful for condensation at sudden temperature change. Condensation makes damage to polarizer or electrical contacted parts. And after fading condensation, smear or spot will occur.
- (5) When fixed patterns are displayed for a long time, remnant image is likely to occur.
- (6) Module has high frequency circuits. Sufficient suppression to the electromagnetic interference shall be done by system manufacturers. Grounding and shielding methods may be important to minimized the interference.

Product Specification

9-3. ELECTROSTATIC DISCHARGE CONTROL

Since a module is composed of electronic circuits, it is not strong to electrostatic discharge. Make certain that treatment persons are connected to ground through wrist band etc. And don't touch interface pin directly.

9-4. PRECAUTIONS FOR STRONG LIGHT EXPOSURE

Strong light exposure causes degradation of polarizer and color filter.

9-5. STORAGE

When storing modules as spares for a long time, the following precautions are necessary.

- (1) Store them in a dark place. Do not expose the module to sunlight or fluorescent light. Keep the temperature between 5° C and 35° C at normal humidity.
- (2) The polarizer surface should not come in contact with any other object.
It is recommended that they be stored in the container in which they were shipped.

9-6. HANDLING PRECAUTIONS FOR PROTECTION FILM

- (1) When the protection film is peeled off, static electricity is generated between the film and polarizer.
This should be peeled off slowly and carefully by people who are electrically grounded and with well ion-blown equipment or in such a condition, etc.
- (2) The protection film is attached to the polarizer with a small amount of glue. If some stress is applied to rub the protection film against the polarizer during the time you peel off the film, the glue is apt to remain on the polarizer.
Please carefully peel off the protection film without rubbing it against the polarizer.
- (3) When the module with protection film attached is stored for a long time, sometimes there remains a very small amount of glue still on the polarizer after the protection film is peeled off.
- (4) You can remove the glue easily. When the glue remains on the polarizer surface or its vestige is recognized, please wipe them off with absorbent cotton waste or other soft material like chamois soaked with normal-hexane.

Product Specification

APPENDIX A. Enhanced Extended Display Identification Data (EEDID™) 1/3

	Byte	Field Name and Comments	Value	
	(hex)		(hex)	(binary)
Header	0	Header	0 0	0000 0000
	1	Header	F F	1111 1111
	2	Header	F F	1111 1111
	3	Header	F F	1111 1111
	4	Header	F F	1111 1111
	5	Header	F F	1111 1111
	6	Header	F F	1111 1111
	7	Header	0 0	0000 0000
Vendor / Product EDID Version	8	EISA manufacture code = 3 Character ID = LPL	3 2	0011 0010
	9	EISA manufacture code (Compressed ASCII)	0 C	0000 1100
	0A	Panel Supplier Reserved – Product Code	0 0	0000 0000
	0B	Panel Supplier Reserved – Product Code	0 0	0000 0000
	0C	LCD module Serial No - Preferred but Optional (“0” if not used)	0 0	0000 0000
	0D	LCD module Serial No - Preferred but Optional (“0” if not used)	0 0	0000 0000
	0E	LCD module Serial No - Preferred but Optional (“0” if not used)	0 0	0000 0000
	0F	LCD module Serial No - Preferred but Optional (“0” if not used)	0 0	0000 0000
	10	Week of manufacture	0 0	0000 0000
	11	Year of manufacture = 2007	1 1	0001 0001
	12	EDID structure version # = 1	0 1	0000 0001
	13	EDID revision # = 3	0 3	0000 0011
	Display Parameters	14	Video I/P definition = Digital I/P (80h)	8 0
15		Max H image size = 28.608cm(29)	1 D	0001 1101
16		Max V image size = 17.880cm(18)	1 2	0001 0010
17		Display gamma = (2.2× 100) – 100 = 120	7 8	0111 1000
18		Feature support (no DPMS, Active off, RGB, timing BLK 1)	0 A	0000 1010
Panel Color Coordinates	19	Red/Green low Bits	9 6	1001 0110
	1A	Blue/White Low Bits	1 1	0001 0001
	1B	Red X = 0.592	9 7	1001 0111
	1C	Red Y = 0.345	5 8	0101 1000
	1D	Green X = 0.333	5 5	0101 0101
	1E	Green Y = 0.541	8 A	1000 1010
	1F	Blue X = 0.160	2 9	0010 1001
	20	Blue Y = 0.149	2 6	0010 0110
	21	White X = 0.313	5 0	0101 0000
	22	White Y = 0.329	5 4	0101 0100
Established Timings	23	Established timings 1 (00h if not used)	0 0	0000 0000
	24	Established timings 2 (00h if not used)	0 0	0000 0000
	25	Manufacturer’s timings (00h if not used)	0 0	0000 0000
Standard Timing ID	26	Standard timing ID1 (01h if not used)	0 1	0000 0001
	27	Standard timing ID1 (01h if not used)	0 1	0000 0001
	28	Standard timing ID2 (01h if not used)	0 1	0000 0001
	29	Standard timing ID2 (01h if not used)	0 1	0000 0001
	2A	Standard timing ID3 (01h if not used)	0 1	0000 0001
	2B	Standard timing ID3 (01h if not used)	0 1	0000 0001
	2C	Standard timing ID4 (01h if not used)	0 1	0000 0001
	2D	Standard timing ID4 (01h if not used)	0 1	0000 0001
	2E	Standard timing ID5 (01h if not used)	0 1	0000 0001
	2F	Standard timing ID5 (01h if not used)	0 1	0000 0001
	30	Standard timing ID6 (01h if not used)	0 1	0000 0001
	31	Standard timing ID6 (01h if not used)	0 1	0000 0001
	32	Standard timing ID7 (01h if not used)	0 1	0000 0001
	33	Standard timing ID7 (01h if not used)	0 1	0000 0001
	34	Standard timing ID8 (01h if not used)	0 1	0000 0001
35	Standard timing ID8 (01h if not used)	0 1	0000 0001	

Product Specification

APPENDIX A. Enhanced Extended Display Identification Data (EEDID™) 2/3

Timing Descriptor #1	36	1280X800 @60Hz mode pixel clock (LSB) => 71.5MHz	E E	1110 1110
	37	(Stored LSB first)	1 B	0001 1011
	38	Horizontal Active = 1280 pixels (lower 8bits)	0 0	0000 0000
	39	Horizontal Blanking = 160 pixels (lower 8bits)	A 0	1010 0000
	3A	Horizontal Active : Horizontal Blanking (upper 4:4bits)	5 0	0101 0000
	3B	Vertical Active = 800 lines (lower 8bits)	2 0	0010 0000
	3C	Vertical Blanking = 27 lines (lower 8bits)	1 B	0001 1011
	3D	Vertical Active : Vertical Blanking (upper 4:4bits)	3 0	0011 0000
	3E	Horizontal Sync. Offset = 48 pixels	3 0	0011 0000
	3F	Horizontal Sync Pulse Width = 32 pixels	2 0	0010 0000
	40	Vertical Sync Offset = 3 lines : Sync Width = 6 lines	3 6	0011 0110
	41	Horizontal Vertical Sync Offset/Width upper 2bits = 0	0 0	0000 0000
	42	Horizontal Image Size = 286.08mm(286)	1 E	0001 1110
	43	Vertical Image Size = 178.80cm(179)	B 3	1011 0011
	44	Horizontal & Vertical Image Size	1 0	0001 0000
	45	Horizontal Border = 0	0 0	0000 0000
	46	Vertical Border = 0	0 0	0000 0000
47	Non-interlaced,Normal display,no stereo,Digital separate sync,H/V pol negatives	1 8	0001 1000	
Timing Descriptor #2	48	Not used	0 0	0000 0000
	49	Not used	0 0	0000 0000
	4A	Not used	0 0	0000 0000
	4B	Not used	0 0	0000 0000
	4C	Not used	0 0	0000 0000
	4D	Not used	0 0	0000 0000
	4E	Not used	0 0	0000 0000
	4F	Not used	0 0	0000 0000
	50	Not used	0 0	0000 0000
	51	Not used	0 0	0000 0000
	52	Not used	0 0	0000 0000
	53	Not used	0 0	0000 0000
	54	Not used	0 0	0000 0000
	55	Not used	0 0	0000 0000
	56	Not used	0 0	0000 0000
	57	Not used	0 0	0000 0000
	58	Not used	0 0	0000 0000
59	Module "A" Revision = 00 Example: 00, 01, 02, 03, etc.	0 0	0000 0000	
Timing Descriptor #3 Dell specific information	5A	Flag	0 0	0000 0000
	5B	Flag	0 0	0000 0000
	5C	Flag	0 0	0000 0000
	5D	Dummy Descriptor	F E	1111 1110
	5E	Flag	0 0	0000 0000
	5F	Dell P/N 1 st Character = U	5 5	0101 0101
	60	Dell P/N 2 nd Character = N	4 E	0100 1110
	61	Dell P/N 3 rd Character = 8	3 8	0011 1000
	62	Dell P/N 4 th Character = 6	3 6	0011 0110
	63	Dell P/N 5 th Character = 4	3 4	0011 0100
	64	LCD Supplier EEDID Revision #	0 6	0000 0110
	65	Manufacturer P/N = 1	3 1	0011 0001
	66	Manufacturer P/N = 3	3 3	0011 0011
	67	Manufacturer P/N = 3	3 3	0011 0011
68	Manufacturer P/N = W	5 7	0101 0111	
69	Manufacturer P/N = X	5 8	0101 1000	
6A	Manufacturer P/N = 1	3 1	0011 0001	
6B	Manufacturer P/N (If <13 char, then terminate with ASCII code 0Ah, set remaining char = 20h)	0 A	0000 1010	

Product Specification

APPENDIX A. Enhanced Extended Display Identification Data (EEDID™) 3/3

Timing Descriptor #4	6C	Flag	0 0	0000 0000
	6D	Flag	0 0	0000 0000
	6E	Flag	0 0	0000 0000
	6F	Data Type Tag:	F E	1111 1110
	70	Flag	0 0	0000 0000
	71	SMBUS Value = 10 nits	1 F	0001 1111
	72	SMBUS Value = 17 nits	3 6	0011 0110
	73	SMBUS Value = 24 nits	4 2	0100 0010
	74	SMBUS Value = 30 nits	4 C	0100 1100
	75	SMBUS Value = 60 nits	6 B	0110 1011
	76	SMBUS Value = 100 nits	8 A	1000 1010
	77	SMBUS Value = 160 nits	B 2	1011 0010
	78	SMBUS Value = max nits (Typically = FFh, 220 nits)	F F	1111 1111
	79	Number of LVDS receiver chips = '01' or '02'	0 1	0000 0001
7A	BIST Enable: Yes = '01' No = '00'	0 1	0000 0001	
7B	(If <13 char, then terminate with ASCII code 0Ah, set remaining char = 20h)	0 A	0000 1010	
7C	(If <13 char, then terminate with ASCII code 0Ah, set remaining char = 20h)	2 0	0010 0000	
7D	(If <13 char, then terminate with ASCII code 0Ah, set remaining char = 20h)	2 0	0010 0000	
Checksum	7E	Extension flag (# of optional 128 EDID extension blocks to follow, Typ = 0)	0 0	0000 0000
	7F	Checksum	8 A	1000 1010